

MANAGING WILD PIGS

A TECHNICAL GUIDE

Ben C. West
Andrea L. Cooper
James B. Armstrong



HUMAN-WILDLIFE INTERACTIONS MONOGRAPH
NUMBER 1



ACKNOWLEDGMENTS

As with any such endeavor, we are indebted to a large number of people and organizations for their support of this publication and their assistance in bringing it to fruition. We thank the Berryman Institute, Mississippi State University, Utah State University, Auburn University, USDA/APHIS/Wildlife Services, the Alabama Wildlife Federation, the Wildlife Damage Working Group of The Wildlife Society, the Renewable Resources Extension Act (RREA), and the Association of Fish and Wildlife Agencies for their financial and moral support of this publication. Frank Boyd was instrumental to the original concept for this publication and continued to provide valuable advice and guidance during its development. Michael Conover was key to this guide being published as part of the new Monograph series of the journal *Human-Wildlife Interactions*. We could not have possibly produced this document without the able assistance of our designer, Kathy Jacobs, and our editor, Tom Knecht; the quality of this publication is due in large part to their efforts. Many people generously provided photographs and illustrations, including Carol Bannerman, Tyler Campbell, Steve Gullede, Billy Higginbotham, Chris Jaworowski, Dana Johnson, Dan McMurtry, Eddie Parham, Rod Pinkston, and the Southeastern Cooperative Wildlife Disease Study. Finally, we benefitted greatly from comments and suggestions on drafts provided by Carol Bannerman, Jerry Belant, Tyler Campbell, Joe Corn, Rob Denkhaus, Stephen Ditchkoff, John Dunlap, Kris Godwin, Bill Hamrick, Ed Hartin, Billy Higginbotham, Skip Jack, Chris Jaworowski, Dana Johnson, Steven Lapidge, Jack Mayer, Dan McMurtry, Gary Moody, Jim Miller, Rod Pinkston, and Ron Regan. Their generous sharing of time and expertise added immeasurably to the accuracy and completeness of this publication.

The mention of commercial products in this publication is for the reader's convenience and is not intended as an endorsement of those products nor discrimination against similar products not mentioned.

This publication should be cited as:

West, B. C., A. L. Cooper, and J. B. Armstrong. 2009. *Managing wild pigs: A technical guide*. *Human-Wildlife Interactions Monograph* 1:1–55.

To obtain additional copies of this publication, please visit www.berrymaninstitute.org/publications, where an electronic copy may be downloaded at no charge. Printed copies may also be ordered at that website for a nominal shipping and handling fee.

ISBN# 0-9742415-1-2

Published by The Berryman Institute

Starkville, MS and Logan, UT

Several cover photos provided by Steve Gullede and Chris Jarowski

Editing by Tom Knecht, Words by Tom

Design and Layout by Kathy Jacobs Design & Marketing

CONTENTS

Preface	1
Wild Pigs in North America	3
Biology and Natural History	5
Range	5
Physical Characteristics	6
Breeding and Reproduction.....	8
Dispersal	9
Home Range	12
Mortality and Survival.....	13
Feeding Habits	13
Wild Pig Damage	15
Ecological Damage.....	15
Agricultural Crops	16
Livestock.....	17
Damage to Forest Restoration.....	18
Disease Threats to Humans and Livestock.....	18
Swine Brucellosis.....	19
Pseudorabies	20
Classical Swine Fever	20
Trichinosis.....	21
Damage Management Techniques	22
Legal Considerations.....	23
Population Dynamics and Management Strategies	23
Lethal Techniques.....	24
Trapping	24
Bait.....	25
Cage Traps.....	26
Door Designs.....	27
Trigger Designs.....	29
Putting It All Together: Three Trap Designs	29
Snares	32
Shooting and Hunting.....	33
Aerial Shooting	33
Night Shooting	34
Judas Pig.....	35

Hunting With Dogs.....	36
Toxicants	37
Nonlethal Techniques.....	38
Fencing	38
Harassment.....	39
Vaccination.....	39
Contraception.....	39
Summary	41
Literature Cited	43
Appendix	51
Authors	54



Chris Jaworowski

Since their introduction to North America, wild pigs have become one of the more serious wildlife problems in the United States.

PREFACE

This manual was written to help people, especially natural resource professionals, who are interested in managing wild pigs (*Sus scrofa*). However, we expect that it will be read by a wide variety of people, including wildlife biologists, land managers, farmers, hunters, policymakers, academicians, and others. Given this diversity of readership, developing this guide was a balancing act between offering detailed information supported by the scientific literature on the one hand and summarizing as simply as possible what is known about wild pigs and their management on the other. In the end, we are hopeful that the publication is detailed enough to be useful to those with a deep interest in wild pigs but also succinct enough for those simply interested in a comprehensive management resource.

Since their introduction to North America, wild pigs have become one of the more serious wildlife problems in the United States. Conover (2002) opines that the vast majority of wildlife in North America have many positive values that ultimately outweigh the costs of the problems they may cause and thus provide a net benefit to society. From that perspective, wildlife damage management is the strategy of alleviating problems sometimes caused by wildlife while retaining or enhancing their positive benefits. Conover (2002) further explains, however, that a few wildlife species cause problems that outweigh their positive values and should be considered pests. Although we recognize that wild pigs provide recreational benefits to some hunters and landowners (see Rollins

et al. 2007), one could argue that the scope and severity of problems caused by pigs outweigh their benefits in many areas. In these cases, managers may decide that population reduction or eradication is the preferred management objective, and we created this manual to support such efforts.

While there is a technical distinction between Eurasian wild boars, feral pigs, and their hybrids, all have similar impacts on ecosystems, native wildlife, agricultural commodities, and other resources. Thus for the sake of practicality we use the term “wild pigs” to refer collectively to feral pigs, Eurasian wild boars, and hybrids. Please note, however, the information herein is not intended for management of the collared peccary (javelina; *Tayassu tajacu*), a native inhabitant of the American Southwest, Mexico, and Central and South America.

The body of scientific work regarding wild pigs is impressive, particularly in the arenas of natural

history, biology, ecology, and environmental impact. Wolf and Conover (2003) and, more recently, Mayer and Shedrow (2007) have compiled excellent bibliographies for individuals wanting an exhaustive review of all the scientific literature pertaining to wild pigs. Despite this abundance of scientific literature, many questions remain about the effective management of wild pigs, and managers must often invent techniques and strategies on the fly.

Because we intend this as a technical guide for management, we have included both references to the scientific literature and anecdotal information from the field. Many of the management options we discuss have been largely untested by the rigors of scientific investigation, and we expect researchers to continue testing and refining those and other techniques. In the meantime, we recognize that management is both art and science, and both are equally valid and important to individuals interested in managing wild pigs.



Chris Jaworowski

Today, wild pigs are both numerous and widespread throughout North America.

WILD PIGS IN NORTH AMERICA

Wild pigs are not native to the Americas (Mayer and Brisbin 1991). Pigs are thought to have been first domesticated from the Eurasian wild boar about 8,000 to 10,000 years ago (Barrett 1978, Larson et al. 2005, Minagawa et al. 2005). In addition, new genetic data have revealed a history of widespread multiple centers of independent pig domestications across Eurasia (Giuffra et al. 2000, Larsen et al. 2005). Given their adaptability and ability to survive in the wild, they were a popular livestock for American settlers colonizing new areas and were probably first introduced into the New World by Christopher Columbus in 1493 in the West Indies. In the ensuing centuries, pigs were released throughout the United States, particularly in the southeastern states (Hanson and Karstad 1959, Wood and Lynn 1977, Mayer and Brisbin 1991). Following the initial flurry of releases throughout the 1500s, settlers, farmers, and Native Americans promoted the spread of pigs by open range practices that persisted in some states as recently as the 1960s. By the early 1980s, wild pigs ranged from the Coastal Plain of Virginia south to Florida, and west to Texas and California (Sweeney and Sweeney 1982). Today, though the range of wild pigs appears to be continually expanding, the South remains the epicenter of wild pig populations.

The establishment of Eurasian wild boar populations occurred mostly after the release of domestic pigs into the wild. The establishment of a boar population in the wild likely first occurred when some were brought to North Carolina from Germany in 1912 for hunting purposes

(Jones 1959); descendants from this population were later introduced into California in 1925 or 1926 (Bruce 1941, Seymour 1970; Pine and Gerdes 1973). More recently, Eurasian wild boars were introduced into other areas of the United States, and many hybrid populations occur throughout the range of wild pigs as a result of cross-breeding. Pure strains of Eurasian boar reportedly are rare; nevertheless, at least a few small localized populations of pure animals exist in the United States (e.g., Michigan), having originated from farm-raised wild boar brought down from Canada (Mayer 2009).

Today, wild pigs are both numerous and widespread throughout North America. It is exceedingly difficult to conduct population censuses of any species of wildlife, including wild pigs. This difficulty, coupled with ongoing population growth and range expansion of wild pigs, makes it nearly impossible to estimate the number of wild pigs in

the United States and to definitively state where they do and do not occur. Regardless, evidence is compelling that wild pigs are abundant in many areas and are expanding their range into areas heretofore not occupied. As early as the 1950s, concentrations of wild pigs in the Southeast were high, though the reported density of 75 to 100 animals per square mile (Hanson and Karstad 1959) was probably unrealistic and a result of poor population estimation techniques. Nevertheless, pigs are numerous, so much so that several decades ago Decker (1978) reported wild pigs to be the most abundant, free-ranging, introduced ungulate in the United States. Mayer and Brisbin (1991) suggested a United States population between 1 and 2 million wild pigs in 1991, but that number quickly became obsolete and the current population is likely much greater; for example, Taylor (2003) speculated that the wild pig population in Texas alone numbered 1.5 million animals.



Wild pigs are remarkable in the diversity of their physical appearance and behavior.

BIOLOGY & NATURAL HISTORY

Wild pigs are remarkable in the diversity of their physical appearance and behavior. The purpose of this publication is not to provide an exhaustive review of the substantial body of literature on the natural history and biology of wild pigs but to provide sufficient information to understand the basic character of the animal. Readers interested in greater detail about wild pig biology, natural history, and behavior should turn to the excellent summaries by Mayer and Brisbin (1991), Sweeney et al. (2003), and Mayer and Brisbin (2009).

RANGE

Because wild pigs are highly adaptable, suitable habitat occurs throughout much of North America. Since their introduction in the southeastern United States, wild pigs have expanded their range to many other regions of the country, particularly in the past few decades. The Southeastern Cooperative Wildlife Disease Study (SCWDS) has monitored wild pig populations since 1982 and has documented a steady advance into new regions (www.uga.edu/scwds/dist_maps.htm); currently, pigs exist in at least 39 states (Fogarty 2007, Gipson et al. 1998). Although many have presumed that pigs were a southern species and that harsh winters would limit their expansion northward, pig populations now exist in the northerly climates of Michigan and North Dakota.

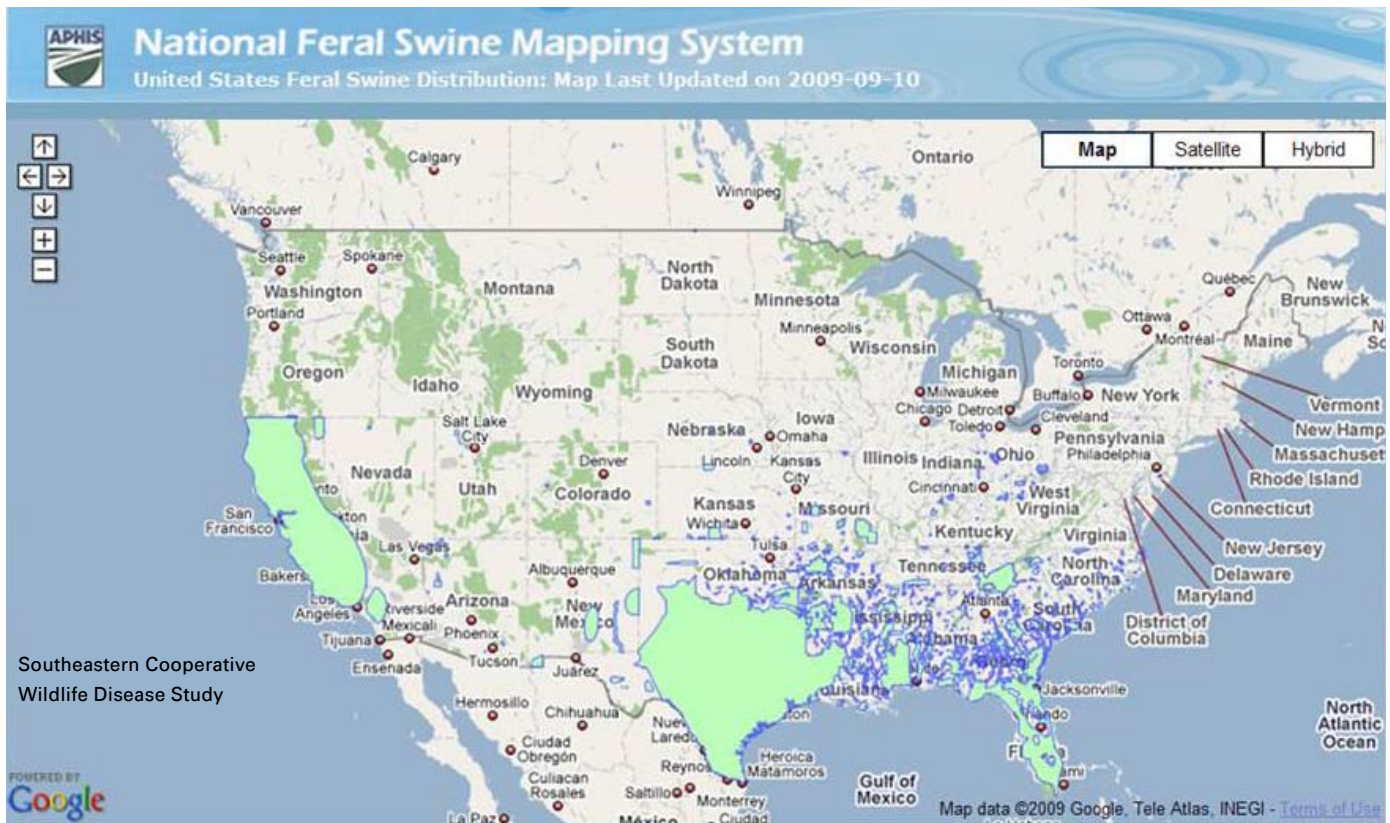

Wild pigs are numerous and widespread across the country. The Southeastern Cooperative Wildlife Disease Study (SCWDS) has monitored wild pig populations since 1982 and has documented a steady advance into new regions. Recently, SCWDS has created a dynamic mapping system to monitor the expansion of pig populations continuously. For more information, visit www.feralswinemap.org.

The SCWDS has created a dynamic online database to monitor wild pig distribution in the United States (www.feralswinemap.org). Wildlife professionals with state and federal agencies continually provide data for the online database, and it thus represents a potentially valuable tool for monitoring the distribution and expansion of wild pigs in North America. However, the ultimate accuracy and hence value of this tool is dependent upon the participation and input of natural resource professionals nationwide, so they are encouraged to contribute data about pig distribution in their state and region.

PHYSICAL CHARACTERISTICS

Wild pigs come in all colors, shapes, and sizes. Because of their varied ancestry,



Once thought to be primarily a southern species, pigs have been expanding their range and now exist in many northern climates.

individual wild pigs vary widely in physical appearance and morphometrics. Although some differences exist among Eurasian wild boars, wild pigs of domestic ancestry, and hybrids (Mayer and Brisbin 1991), these differences are mostly unimportant from a

management perspective and will not be discussed in detail here. Readers interested in more information about the differences in the Eurasian wild boar and other wild pigs should examine Mayer and Brisbin (1991), Mayer and Brisbin (1993), and Sweeney et al. (2003).

Wild pigs most frequently are blackish in color, but individuals may be nearly any color or combination of colors. Eurasian wild boars typically have a coat of brown to black hairs with white or tan distal tips (i.e., grizzled coloration), whereas wild pigs from domestic ancestry are characterized by uniformly colored hair (Mayer and Brisbin 1991). Furthermore, pelage color can be variable throughout the life of an individual. For example, some young wild boars have a striped juvenile coat coloration that disappears with age and changes to the aforementioned adult grizzled coat coloration pattern. In contrast, other wild piglets can have a coat similar in color to that of adults from the same population (Mayer and Brisbin 1991, 1993).

Pigs have 44 permanent teeth, and the development of the upper and lower canines of males are of particular interest (Sweeney et al. 2003). These teeth grow continually and, because of friction between the upper and lower canines, can become quite sharp, particularly the lower canines. These canines, or tusks, can grow to 4 inches or more in length out of the socket (Mayer and Brisbin 1988) and are at the heart of much of the lore about wild pigs. Fighting among rival mature males for breeding opportunities is the apparent evolutionary cause of the size difference seen between the sexes in wild pig tusks (Herring 1972). Such male-male fights can be fierce, and tusk scars are common on the bodies of adult boars.



Eddie Parham



Chris Jaworowski

Wild pigs come in a variety of colors and patterns, ranging from black to multicolored.



Chris Jaworowski

The lower canines or tusks of male wild pigs can grow quite long and sharp. These tusks are used in bouts with rival males and are at the heart of much of the lore about wild pigs.

Individual wild pigs vary widely in their physical dimensions and weight, depending on their ancestry and local environment. As a general rule, males are larger and weigh more than females, but much overlap exists. Average total lengths (measured from the tip of the nose to the end of the fleshy part of the tail) for adult wild pigs range from about 50 to 75 inches, and average weights from about 75 to 250 pounds (Sweeney 1970, Mayer and Brisbin 1991).

Individual wild pigs can grow quite large, depending on available food resources. For example, one pig killed in South Carolina tipped the scale at 893 pounds (Rutledge 1965). Records are challenged quite often, most famously by "Hogzilla," a supposedly gigantic wild pig shot in southern Georgia. The original Hogzilla was claimed to weigh in excess of 1,000 pounds and be 12 feet in length, but the pig was buried before these assertions could be verified. National Geographic, curious about the outrageous claims, assembled a research team to exhume the carcass and estimate its live size and weight. They concluded that Hogzilla was real, but researchers estimated the live weight to be about 800 pounds and the total length to be between 7.5 and 8 feet (Minor 2005). When such gigantic pigs are reported, it is almost always the result of people feeding captive pigs, growing them to enormous sizes, and then releasing them into the wild.

BREEDING AND REPRODUCTION

Wild pigs are perhaps the most prolific large mammal on Earth. Pig populations can grow rapidly in good habitat, and this population growth and subsequent dispersal can result in pigs quickly colonizing and populating new areas (Waithman et al. 1999). Such impressive growth capability is possible because pigs possess traits that yield high recruitment rates. To a large extent, these traits are an artifact of their domestic heritage, namely that, (1) pigs reach sexual maturity at a young age, (2) females can farrow multiple times a year, (3) females can have large litters, and (4) natural mortality rates often are relatively



Piglets often have striped coats; the striping typically disappears as they age.

low. Good habitat conditions can enhance all of these characteristics and result in irruptive population growth (Bieber and Ruf 2005).

Wild pigs are perhaps the most prolific large mammal on earth.

Puberty occurs early in wild pigs, particularly under good habitat conditions. In general, puberty occurs between 6 and 10 months of age (Barrett 1978), although Giles (1980) reported puberty in wild females as young as 3 months. Although females begin breeding as soon as puberty occurs, sexually mature males are often prohibited from breeding by older, more dominant individuals (Barrett 1978).

Wild pigs are physiologically capable of reproducing twice each year, although individuals in most populations produce only a single litter annually (Springer 1977, Taylor et al. 1998). Wild pigs can breed year-round, and farrowing has been observed throughout the year. Nevertheless, most

populations exhibit breeding patterns in which farrowing peaks during winter and early spring and occurs again in a secondary period in midsummer (Barrett 1978, Sweeney et al. 1979, Taylor et al. 1998), although this timing may vary with locale (Sweeney et al. 2003).

Domestic pigs have been selectively bred for large litters, and this trait remains in feral populations. Although individual sows may sometimes have litters of ≥ 10 piglets, litter sizes in the wild typically range from 3 to 8. Litter size may increase in association with greater female body size, condition, and habitat quality (Sweeney et al. 2003, Bieber and Ruf 2005). Wild pigs with Eurasian wild boar ancestry tend to have slightly smaller litters than pigs from domestic ancestry, with most wild boar females farrowing litters of 4 to 5 piglets (Sweeney et al. 2003). Like other reproductive traits, litter sizes, and thus reproductive potential, increase with improved habitat quality (Bieber and Ruf 2005).

DISPERSAL

Social structures in wild pig populations are characterized by lone males and groups (often called "sounders") of females and piglets. These sounders consist of up to 3 related generations and typically number 8 or fewer individuals with 1 to 3 adults. Piglets normally are weaned around 3 months of age, at which time individual yearling females either remain with the group or begin the process of dispersal. Kaminski et al. (2005) reported that most yearling females (79%) remained with their family group, and this arrangement appears to be an all-or-nothing proposition; female yearlings in a group either all dispersed



Wild pig populations have incredible potential for growth. In good conditions, adult females can farrow multiple times a year and produce large litters, and juvenile females can breed at an early age. As a result, pig populations can quickly grow and expand their range.



Wild pigs generally travel in large family groups, often called "sounders," consisting of several adult females and multiple juveniles.

Wild pigs leave field signs that are unique and identifiable, thus making it relatively easy to determine whether wild pigs inhabit an area.



Chris Jaworowski

Rooting is the most common and recognizable field sign created by wild pigs.



Chris Jaworowski

Wild female pigs in southern swamps construct nests or beds by cutting and piling palmetto fronds to protect their young from weather and predation. In other areas leaves, grasses, and twigs may be used and placed over a small depression in the ground.



Chris Jaworowski

Pigs create wallows to cool their body temperature and rid themselves of biting insects.



Chris Jaworowski

Wild pigs deposit characteristic scat that is a reliable sign of their presence in an area.

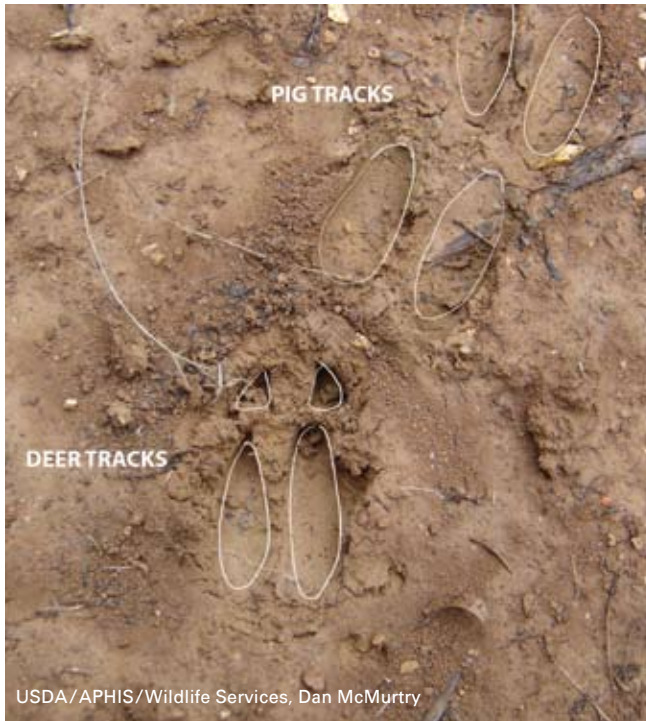

USDA/APHIS/Wildlife Services, Dan McMurtry

Tracks left by wild pigs and white-tailed deer often are easily identified. Pig tracks are generally more rounded at the tips of the hooves, and they often display more widely spread dew claws.



Chris Jaworowski

Sometimes, though, it can be difficult to distinguish between them. This track, left by a wild pig, could easily be mistaken for that of a white-tailed deer.



Eddie Parham

Mud rubs on trees are a good indicator of the presence of wild pigs. They rub on trees to remove excess mud from their coats after wallowing. Mud rubs on trees can give you an idea as to the relative size of pigs in your area. Mud rubs that are 3 to 4 feet off the ground indicate the presence of mature pigs.



Eddie Parham

As part of their scent marking behavior, male wild pigs use their tusks to remove the bark and expose the wood of small trees.

or all remained with the family group. Females that disperse usually do so with their sisters and create another family group together. Males essentially always disperse from the family group, usually around 16 months of age (Gabor et al. 1999).

HOME RANGE

Wild pigs are opportunistic generalists with regard to diet and habitat; consequently, their home range size may depend on a number of factors, including habitat quality, food availability, and population density. The average home range size for wild pigs in North America varies from a few hundred to several thousand acres (Kurz and Marchinton 1972, Singer et al. 1981, Baber and Coblenz 1986; Boitani et al. 1994, Hayes 2007, Gaston 2008). Poor habitat quality, limited food availability, and low population density lead to larger home ranges. Human activity can greatly impact home ranges, as pigs reduce movements and home ranges in situations where human activity is high (Wood and Brenneman 1980, Hayes 2007, Gaston 2008).

Within their annual home range, wild pigs are almost nomadic and have seasonal home ranges that may or may not overlap. Gender and age seem to have little impact on the size of wild pig home ranges, although Saunders and McLeod (1999) did report that body mass was positively correlated to home range size in these animals. Although many factors influence the seasonal movements of pigs, food availability is of primary importance, followed by thermoregulation needs. Pigs have no functional sweat glands, so they are sensitive to high temperatures and rely on behavioral adaptations to cope with hot weather. The impact of temperature on seasonal movements is not clear, though some have reported that pigs shift summer home ranges to areas with cooler ambient temperatures and with greater availability of water (Hughes 1985). The impact of temperature on daily movements is much clearer, as thermoregulation greatly influences daily movements

and can lead to nocturnal behavior during summer months (Sweeney et al. 2003).

Geist (1977) reasoned that Suids should exhibit territorial behavior, but evidence for such in wild pig populations has been mixed. Some studies have found that female home ranges overlapped, and some have thus concluded that female wild pigs are not territorial (Barret 1978, Graves 1984, Baber and Coblenz 1986, Boitani et al. 1994). More recent studies, though, have hypothesized that while females within a particular sounder are not territorial, sounders as a group do indeed establish and defend territories. Boitani et al. (1994) reported that sounders did not hold territories and instead had overlapping home ranges, whereas Ilse and Hellgren (1995) and Gabor et al. (1999) did document exclusive home ranges and thus evidence for territoriality. Sparklin et al. (2009) specifically studied the territoriality of sounders, and concluded that wild pigs are territorial on the level of sounders but not individuals. Questions yet remain about the



Chris Jaworowski

Although many have debated the role of territoriality in the ecology of wild pigs, recent research has shown that while wild pigs may not be territorial on the individual level, they do appear to be so on the sounder level.

impact of resource availability on pigs' tendencies toward territorial behavior.

MORTALITY AND SURVIVAL

In most areas and populations, the most significant cause of mortality in wild pigs is hunting. However, because of their prolificacy, wild pig populations in good habitats can endure extremely high rates of hunting harvest (Barrett and Pine 1980), and in most cases hunting alone cannot control populations. Bieber and Ruf (2005) estimated that, in good habitat conditions, adult survival would have to be reduced to <10% to counter population growth. In some cases, hunting has had a significant impact on pig populations (Belden and Frankenberg 1989, Belden 1997), but it is unclear how the impact of hunting mortality interacts with and is influenced by habitat quality. In addition to direct mortality, the effects of high pressure from humans (either hunting pigs or hunting other game) may indirectly reduce survival of pigs, regardless of gender or age (Gaston 2008).

Wild pig populations in good habitats can endure extremely high rates of hunting harvest.

Predation has little impact on most pig populations, although researchers have documented predation by alligators, black bears, and mountain lions (Sweeney et al. 2003). Indeed, in some specific situations, wild pigs can represent a significant prey item, as Maehr et al. (1990) documented in Florida panthers. The impact of disease and parasites on wild pig populations is poorly understood, though it probably can be substantive in specific situations. Disease seems to pose the greatest risk to both young (<6 months) and older (>2 years) individuals, though this, too, is largely speculative (Sweeney et al. 2003).



When available, mast is a common food item for wild pigs. In some cases, pigs may outcompete native wildlife for these food resources.

FEEDING HABITS

Wild pigs are opportunistic omnivores that feed primarily by rooting and grazing, which contributes to their role as a problematic species. Their rooting behavior, in particular, is a principal reason they are considered a pest. Schley and Roper (2003) summarized diet analyses in 21 different articles based on research conducted across 8 European countries and noted that wild pigs will eat almost any organic substance, depending on availability. Sweeney et al. (2003) likewise provided an overview of wild pig feeding studies, all of which reported an incredibly varied diet. Even so, some generalizations can be made. Vegetation certainly dominates pig diets — in volume, $\geq 85\%$ of wild pigs' diet is composed of vegetable matter — but animals, both vertebrate and invertebrate, also constitute a regular food item (Schley and Roper 2003). Invertebrates represent prominent food items for wild pigs; insects and earthworms commonly show up in stomach contents. Researchers sometimes find larger mammals in wild pig stomachs, presumably as a result of scavenging. More

commonly, though, pigs consume small mammals and herptiles, sometimes from scavenging, sometimes from direct predation (Schley and Roper 2003, Wilcox and Van Vuren 2009).

Evidence suggests that wild pigs are largely indiscriminate in their food selection. Some researchers have suggested that pigs prefer mast when available, particularly acorns, although others argue this interannual variation is only reflective of forage availability, not diet preference (Barrett 1978, Belden and Frankenberger 1990, Schley and Roper 2003). Whatever the case, it is clear that mast constitutes a very common food item when available and that its annual availability has a significant impact on the body condition, reproductive potential, and movement patterns of wild pigs (Wood and Brenneman 1980, Baber and Coblenz 1987, Jedrzejewska et al. 1997). Some have suggested that wild pigs compete with

other, more desirable wildlife species for mast, but such competition has not been fully documented (Sweeney et al. 2003).

Finally, wildlife researchers and managers have long speculated about the impact of wild pigs on ground-nesting birds, particularly as it relates to nest predation. Without question, wild pigs do sometimes consume eggs and chicks (Thompson 1977, Tolleson et al. 1993); still, little conclusive evidence exists to suggest that pigs prefer these or any other food item. Most likely, pigs consume eggs and chicks at a rate proportional to incidental encounter, and in areas with dense pig populations, this incidental consumption could be problematic. Be that as it may, researchers are undecided about the impact of wild pigs on populations of ground-nesting birds. Future research may bring clarity to this issue.



Chris Jaworowski

Wild pigs are perhaps the greatest vertebrate modifiers of natural plant communities.

WILD PIG DAMAGE

ECOLOGICAL DAMAGE

Wild pigs cause problems in North American ecosystems in a variety of ways, largely because these systems did not evolve with pigs and are not adapted for their rooting behavior (Baber and Coblenz 1986). Impacts to ecosystems can take the form of decreased water quality, increased propagation of exotic plant species, increased soil erosion, modification of nutrient cycles, and damage to native plant species (Patten 1974, Singer et al. 1984, Stone and Keith 1987, Cushman et al. 2004, Kaller and Kelso 2006)

Wild pigs are perhaps the greatest vertebrate modifiers of natural plant communities (Bratton 1977, Wood and Barrett 1979, Stone and Keith 1987). Rooting, trampling, and compaction influence plant regeneration, community structure, soil properties, nutrient cycling, and water infiltration (Seward et al. 2004). Wild pigs may induce the spread of invasive plant species because invasive exotics typically favor disturbed areas and colonize more quickly than many native plants (Hone and Pederson 1980, Coblenz and Baber 1987, Stone and Keith 1987). Habitat damage is particularly important in wet areas where plant communities and soils tend to be more sensitive to disturbance. In Florida, wild pigs contributed to the decline of at least 22 plant species and 4 amphibian species listed as rare, threatened, endangered, or of special concern (USDA 2002). Impacts are particularly significant to endangered species

on islands such as Hawaii where a high number of plant and wildlife species are endemic (Mungall 2001). Recovery of plant communities is sometimes possible after pig populations have been reduced or eliminated, but the species composition of plant communities may be permanently altered.

Pigs can cause problems for native wildlife by competition for resources, direct predation, and the spread of disease and parasites (Hanson and Karstad 1959, Sweeney et al. 2003). Wild pigs may compete with native wildlife for hard and soft mast and many other important food items (Belden and Frankenberger 1989, Yarrow and Kroll 1989). As noted earlier, wild pigs can be significant predators of ground-nesting bird nests (Thompson 1977, Tolleson et al. 1993), although the impact of this predation on the populations of ground-nesting birds is yet unclear. In addition, pigs also prey upon small mammals, salamanders, frogs, fish, crabs, snakes, turtles, and white-tailed deer fawns (Lucas 1977, Hellgren 1993, Jolley 2007, Jolley et al. 2010). In the southeastern United States, wild pigs have become significant



Chris Jaworowski
Wild pig rooting along streams can decrease water quality, increase erosion, and damage sensitive plant communities.

predators of sea turtle eggs on mainland and island beaches along the Atlantic coast (Lewis et al. 1996). Specifically, pigs have threatened the nesting success of several endangered turtles including the loggerhead, green, leatherback, hawksbill, and the Kemp's ridley by destroying up to 80% of nests in some regions of Florida (USDA 2002). Although little scientific literature exists to document the problem, reports from the field indicate that wild pigs have a significant impact on gopher tortoises through habitat degradation and direct predation. This, in turn, may negatively impact Mississippi gopher frogs, eastern indigo snakes, and other species that have a symbiotic relationship with tortoises.

Wild pigs also cause problems in aquatic systems via increased soil erosion and bacterial contamination (Kaller et al. 2007). Wild pig activity in streams has impacted a variety of aquatic flora and fauna, most notably freshwater mussels and insects (Kaller and Kelso 2006, Kaller et al. 2007). Moreover, wild pigs have caused the level of fecal coliforms in some streams to exceed human health standards (Kaller 2005).

AGRICULTURAL CROPS

In addition to impacting ecosystems, wild pigs can damage timber, pastures, and, especially, agricultural crops (Bratton 1977, Lucas 1977, Thompson 1977, Schley and Roper 2003). A conservative estimate of wild pig damage to agricultural crops and the environment in the United States is \$1.5 billion annually (Pimentel et al. 2002, Pimentel 2007). Wild pigs cause damage by directly consuming crops, damaging fields by rooting and digging, and trampling crops (Whitehouse 1999). Pigs will travel long distances to consume attractive foods; one study reported that pigs traveled 6 miles to forage on sorghum (Mungall 2001). In a survey of extension agents in Texas, Rollins (1993) found the most common complaint was damage to crops, including hay, small grains, corn, and peanuts. Crops such as vegetables, watermelons, soybeans, cotton, tree fruits, and conifer seedlings were also affected by wild pigs.

In addition to directly damaging crops, pigs can damage infrastructure such as fences, irrigation ditches, roads, dikes, and other structures. Rooting and wallowing in agricultural fields creates holes that, if unnoticed, can damage farming equipment and pose potential hazards to equipment operators (Nunley 1999).

A conservative estimate of wild pig damage to agricultural crops and the environment in the United States is \$1.5 billion annually.

LIVESTOCK

Wild pigs sometimes prey on livestock, including lambs, goats, newborn cattle, and exotic game. Predation on young livestock animals usually occurs on calving or lambing grounds where wild pigs may be attracted by afterbirth (Beach 1993). Though predation is usually concentrated on young animals, livestock giving birth are sometimes killed and consumed (Wade and Bowns 1985).

Wild pig predation on livestock can be difficult to verify because the entire carcass is usually consumed, leaving little evidence. In addition, pigs will scavenge carcasses killed by other animals. If the whole carcass is not consumed, however, wild pigs usually follow a characteristic feeding pattern that can be used to identify the source of the damage. They typically kill their prey by biting and crushing the skull or neck (Frederick 1998). The carcass typically



Wildlife openings planted in small grains are favored rooting areas for wild pigs in the fall. Rooting damage can lead to equipment damage and costly repairs for land managers.



The aggressive rooting tendencies of wild pigs cause damage to roadsides, dikes, and other earthen structures.

will be skinned and the rumen or stomach contents consumed (Wade and Bowns 1985). Obviously, wild pig tracks and scat in the immediate vicinity can help identify incidents of predation.

In addition to directly preying on livestock, wild pigs can cause damage to livestock fencing. Because of their size and strength, wild pigs can damage even robust fences, thus compromising the fence's ability to contain livestock and exclude predators. Although no one has estimated the economic impact of this damage, it has potential to be significant in terms of fence repair costs and escaped livestock (Beach 1993).

DAMAGE TO FOREST RESTORATION

Hard mast (e.g., acorns and hickory nuts) is an important food source for wild pigs; thus attempting to regenerate hardwoods from seed may be difficult if pigs are present. In areas where mast or fruit have already germinated, rooting activities may dislodge and damage young seedlings. In some areas, rooting significantly reduces oak regeneration (Huff 1977, Sweitzer and VanVuren 2002). Rooting also accelerates decomposition of leaf litter, resulting in a loss of nutrients from the forest floor and upper soil horizons (Singer et al.



USDA/APHIS/Wildlife Services, Carol Bannerman

Wild pigs can quickly damage pasturelands while rooting for earthworms, grubs, roots, and tubers. Their rooting can reduce the production of forage, as well as make the harvest of hay difficult or impossible. Rooting damage can also lead to damage of hay cutters and baling equipment.



Steve Gullede

Wild pigs can cause significant damage to forests. Perhaps most important, they can impair regeneration through consumption of mast and the destruction of seedlings, particularly those of longleaf pines.

1984), which may make it more difficult for seedlings to grow and survive.

Seedlings of both hardwoods and pines, especially longleaf pines, are very susceptible to pig damage through direct consumption, rooting, and trampling (Whitehouse 1999, Mayer et al. 2000, Campbell and Long, 2009). This is problematic in all forests where it occurs, but particularly in longleaf pine forests, an ecosystem already in peril. Longleaf pines dominated about 92 million acres in the United States before European settlement but now occupy less than 3 million acres, mostly in the southeastern region of the country (Landers et al. 1995). The abundant populations of wild pigs across the region have made the restoration and management of longleaf pine forests even more difficult and tenuous.

For some time, wildlife managers questioned whether pigs consumed tree seedlings, given that woody material is seldom found in stomach analyses. However, researchers suspected that pigs chew the roots of seedlings, swallow the sap and starches, and then spit out the woody tissue. To support this idea, researchers have found and documented balls of masticated roots where wild pigs have been rooting among woody plants (Adams et al. 2006).

DISEASE THREATS TO HUMANS AND LIVESTOCK

Wild pigs are capable of carrying numerous parasites and diseases that potentially threaten the health of humans, livestock, and wildlife (Forrester 1991, Williams and Barker 2001, Sweeney et al. 2003,).

Humans can be infected by several of these, including diseases such as brucellosis, leptospirosis, salmonellosis, toxoplasmosis,

sarcoptic mange, *E. coli*, and trichinosis. Diseases of significance to livestock and other animals include pseudorabies, swine brucellosis, tuberculosis, vesicular stomatitis, and classical swine fever (Nettles et al. 1989, Davidson and Nettles 1997, Williams and Barker 2001, Davidson 2006).

Many of the disease management strategies used in the livestock industry, such as vaccinations and animal husbandry, are not an option for wild pigs. Thus wild pigs can serve as a reservoir and amplifier for many diseases, making it difficult or impossible to eradicate disease in livestock and humans in areas with wild pigs (Hone et al. 1992, Corn et al. 2005, Hutton et al. 2006, Wyckoff et al 2009). The role that wild pigs could play in spreading and perpetuating exotic diseases that may emerge in the future is particularly troublesome. For example, foot-and-mouth disease, which was eradicated in the United States in 1929, would be essentially impossible to eradicate again if it reemerges in areas with wild pigs. If foot-and-mouth disease were to reemerge in the United States, it would result in a reduction of \$14 to 21 billion in United States farm income (Paarlberg et al. 2002).

Because of the myriad of viruses, bacteria, and parasites that wild pigs carry and can infect humans, individuals should take precautions to protect themselves from infection when handling them, including either live animals or carcasses. Surgical gloves should always be worn and probably offer sufficient protection for the hunter who handles a pig or two every year. However, the wildlife professional who handles a large number of pigs may opt for more substantive protection, including perhaps a surgical mask, gown or coveralls, and eye protection. At the very least, agencies and organizations involved with the management of wild pigs should educate their employees about the risks of zoonotic diseases, establish protocols for handling these animals, and determine minimum requirements for personal protective equipment when doing so.

A comprehensive discussion of important diseases relative to wild pigs is beyond the scope of this publication. Nevertheless, the following paragraphs



Wild pigs can harbor many diseases that are dangerous to humans, livestock, or other wildlife. The presence of wild pigs in an area can make it difficult or impossible to eradicate certain diseases from livestock, and their contamination of the environment with disease agents can have serious consequences. In 2006, after hundreds of people nationwide were infected with *E. coli* following the consumption of bagged spinach, investigators identified wild pigs as a likely source of the contamination (California Food Emergency Response Team 2007).

provide basic information about a few diseases that hunters, landowners, and farmers commonly inquire about or should be aware of. Those interested in a more detailed and technical summary of disease implications of wild pigs should reference the articles by Davis (1993), Corn et al. (2005), Hutton et al. (2006), and Stallknecht and Little (2009), or the myriad of articles available in the *Journal of Wildlife Diseases*. In addition, the field guides by Davidson and Nettles (1997) and Davidson (2006) provide a broad overview of the causative agents, field signs, and other important aspects of many diseases in wild pigs.

Swine Brucellosis

Swine brucellosis is caused by the bacterium *Brucella suis* and should not be confused with bovine brucellosis, or the diseases found in goats

and dogs caused by other *Brucella* spp. bacteria. This is primarily a reproductive tract disease that causes abortion, stillborn or weak piglets, infertility, inflammation of the testicles, and lameness. Infected animals are long-term carriers. Chronic infection can produce shrunken testicles. Sows can develop small abscesses in the uterine lining that can lead to puss exudate in the uterus. Aborted fetuses often look normal, but the afterbirth may show blood clots and hemorrhages. Transmission of swine brucellosis occurs through ingestion of recently discharged bacteria in aborted fetuses, urine, and semen or via sexual contact (Davidson and Nettles 1997, Davidson 2006).

Swine brucellosis has been found in multiple populations in Arkansas, Alabama, California, Florida, Georgia, Hawaii, Louisiana, Mississippi, South Carolina, and Texas but is likely not limited to these states. The domestic swine industry has endeavored to eradicate brucellosis within domestic populations, but this endeavor is hindered by contact with infected wild pigs (Davidson and Nettles 1997, Davidson 2006).

Human infection by *Brucella* bacteria is possible and not uncommon. Health officials in Florida, for example, documented that 8 of 10 human cases of brucellosis in 2007 were linked to wild pig hunting activities (Florida Department of Health 2008). Humans with the disease typically have flu-like symptoms including intermittent fever, headaches, muscle and joint soreness, and weakness. Though few humans die of infection, the disease is often chronic and debilitating. Hunters should wear rubber gloves and wash with soap as soon as possible after handling a carcass and also ensure the meat is cooked thoroughly before consumption (Davidson and Nettles 1997, Davidson 2006).

Pseudorabies

Infection of pseudorabies, a disease caused by a herpes virus, in wild pigs is common throughout their range in the United States (Stallknecht and Little 2009). In domestic pigs, this disease produces clinical signs that vary from unnoticeable to fatal infections; in wild pigs, though, pseudorabies rarely results in disease or

mortality (Stallknecht and Little 2009). When disease develops, young pigs are most severely affected and often display fever, vomiting, tremors, incoordination, convulsions, and death in most piglets less than 4 weeks old. Adult pigs usually survive but can have fever and upper respiratory tract inflammation. Of particular importance to domestic swine producers, infection in pregnant sows results in abortion or mummified fetuses. In domestic and wild mammals other than swine, the virus produces an acute infection of the central nervous system that produces a loss of appetite, depression, staggering, spasms, and a death rate of nearly 100%. Also known as “mad itch,” pseudorabies infections can cause self-mutilation through persistent scratching, biting, or rubbing (Davidson and Nettles 1997, Davidson 2006).

The virus is spread through nasal or oral secretions, particularly in stressed animals, and through the genitalia. In wild pigs, transmission seems to occur mostly through sexual contact (Romero et al. 2001). Ingestion of infected carcasses can also result in transmission. Other animals that become infected usually die from the disease, which can include cattle, sheep, horses, dogs, cats, foxes, raccoons, skunks, rats, and mice (Davidson and Nettles 1997, Davidson 2006).

Millions of dollars are spent annually to detect and prevent pseudorabies in domestic swine. Because many individuals in wild populations are latent carriers, relocation of wild pigs without appropriate testing threatens to spread the disease and is thus, in most states, illegal. Even in domestic herds, control of pseudorabies is difficult; in wild populations, control of the virus is essentially impossible. Thus the most rational strategy to manage the impact of pseudorabies is to eliminate the transport of live wild pigs and to reduce or eradicate their populations.

Classical Swine Fever

Also commonly known as hog cholera, classical swine fever is a viral disease once prevalent among domestic swine in the United States; however, it was eradicated in the 1970s (Nettles et al. 1989). Affected animals become lethargic, feverish, and lose their appetite.

Vomiting and diarrhea cause animals to become weaker and weaker. This disease generally progresses rapidly, and infected animals usually die 10 to 20 days after exposure. Convulsions may occur in the terminal stage. Chronic infections with milder symptoms can occur, with recovered pigs becoming virus carriers (Davidson and Nettles 1997, Davidson 2006).

Because of its eradication in the United States, classical swine fever is considered a foreign animal disease and must therefore be reported to state or federal animal health authorities for diagnostic investigation. This virus is easily transmitted from pig to pig by direct contact and can also be spread by exposure to contaminated pens, trucks, or feeders (Davidson and Nettles 1997, Davidson 2006).

Trichinosis

Trichinosis is caused by a nematode, or round worm, parasite. Infected wild pigs and other animals rarely show definitive signs of infection. A variety of animals are susceptible to trichinosis, including wild pigs, bears, wolves, wolverines, raccoons, foxes, rats, and

birds. Hosts become infected by eating larvae in the muscle of infected animals. Adult worms live in the intestinal tract, and the larvae form cysts in muscle tissue. More larvae can be found in the most active muscles of the body, including the tongue, diaphragm, jaw, and intercostal muscles. The larvae remain viable for years within muscle tissue until ingested and passed on to the next animal. While trichinosis does not produce illness in wild pigs and other infected animals, it is an important disease because of human infections that cause severe flu-like symptoms and potentially lead to death (Davidson and Nettles 1997, Davidson 2006).

In the past, most cases of trichinosis in humans were caused by consumption of undercooked domestic pork products. However, the incidence of trichinosis in domestic stock has been greatly reduced in recent years due to improved husbandry practices. In wild pigs, though, trichinosis still occurs commonly. As a result, all meat should be handled with gloves and cooked to an internal temperature of 170° Fahrenheit to prevent human infection.



Chris Jaworowski

Most strategies to manage damage caused by wild pigs involve tactics to reduce pig populations.

DAMAGE MANAGEMENT TECHNIQUES

Although several methods can be used to control wild pig populations, individuals with experience in wildlife damage management recognize that many options within the standard suite of management techniques are either unsuitable or ineffective for pigs. Nevertheless, several effective lethal and nonlethal methods exist. Managers must consider their management objectives when deciding which strategies to pursue and which techniques to employ.

Nonlethal methods include exclusion devices such as fences, guard animals to protect livestock, and vaccinations to prevent disease spread. However, guard animals are generally not practical for use against wild pigs in large, brushy pasture situations like the sheep and goat country of Texas (Littauer 1993), and vaccinations are not yet ready for widespread use. Frightening devices are ineffective, and there are no chemical repellents or toxicants registered for wild pig management in the United States (Barrett and Birmingham 1994), although many researchers are trying to develop such options. Habitat manipulation is impractical given the adaptability of the species.

Most strategies to manage damage caused by wild pigs involve lethal control. Lethal methods include trapping, shooting, and hunting with dogs. The efficacy and feasibility of each of these methods is dependent upon the terrain, available labor and funding, and the management objectives.

Certainly, the vast majority of successful efforts to control wild pigs in the United States involve shooting, trapping, or some combination of these methods, and thus these techniques will be described in greatest detail.

LEGAL CONSIDERATIONS

Obviously, individuals interested in managing wild pigs should understand the laws and regulations relevant to their locale. The wild pig problem has evolved rapidly over the past decade or two, both in terms of the pigs' distribution and abundance and in our understanding of the issues. This rapid evolution and increasing complexity, coupled with the fact that wild pig management falls within the jurisdiction of individual state governments, have resulted in a plethora of laws unique to each state, and those laws are rapidly evolving. From a national perspective, the laws and regulations governing the management of wild pigs are complicated and dynamic. As a result, it is not possible in this publication to outline what can and cannot legally be done to control wild pigs. Indeed, any attempt at such an accounting would quickly be rendered obsolete as states continue to form new laws and regulations in an attempt to manage wild pigs and the problems they cause.

Still, some generalizations about the management of wild pigs can be drawn. Typically, state wildlife agencies have jurisdiction over wild pigs, although such authority is held by the agricultural commission in some states. In either case, these agencies generally recognize wild pigs as problematic and in need of intensive management. As a result, state regulations generally make it relatively easy for individuals to conduct pig control activities, especially on private property. Nevertheless, readers should contact the appropriate state wildlife and fisheries agency or agricultural commission with questions about wild pig management in their state. It is also important to monitor changes in regulations throughout the year, as many states are continuing to experiment with rules to encourage and promote pig control.



Hunting for wild pigs is a popular sport, particularly in the South. Although it may be an effective tactic as part of a larger management strategy, recreational hunting alone is unlikely to control wild pig populations. Nevertheless, the stress created by hunting can cause pigs to move away from or restrict their movement within sensitive areas, reducing the likelihood of damage to such areas.

POPULATION DYNAMICS AND MANAGEMENT STRATEGIES

It can be helpful to understand population dynamics of wild pigs while designing and implementing control strategies. Using population modeling, Bieber and Ruf (2005) illustrated the influence of habitat quality on the population growth of wild pigs and thus the likelihood of population control. As mentioned earlier, environmental conditions such as food availability and climatic conditions greatly influence the reproductive capacity of wild pigs, particularly the reproductive capacity of juvenile females. As such, habitat quality has great influence on the potential for population reduction and should be considered when developing and implementing management programs.

In areas with poor habitat and limited food availability, juvenile females generally do not breed. Thus, adult mortality strongly influences the size and growth of wild pig populations in these situations.

In such poor habitat, management programs such as recreational hunting that remove mostly adults have the potential of successfully reducing the population. This may explain why, in some situations, recreational hunting alone has resulted in low pig populations (Belden and Frankenberger 1989, Belden 1997).

The greatest challenge for managers interested in controlling wild pigs occurs in areas with good habitat conditions and abundant food. In these areas and during periods of particularly abundant food (such as during good mast years), juvenile breeding can contribute more to population growth than that of adults (Bieber and Ruf 2005). Under these conditions, even a mortality rate of 90 to 100% of adult females may not cause a population decline, as reproduction in juvenile females would be sufficient to sustain the population. As a result, recreational hunting, which normally removes mostly adult pigs, is usually ineffective as a population control method in good habitat (Hanson et al. 2009). Under such good habitat conditions, managers will have to focus on removing both adults and juveniles, as this is likely the only way to affect a population reduction.

Another implication of the population dynamics of wild pigs is that supplemental food sources can affect management efforts. In areas where supplemental food is consistently available year to year — either in the form of agricultural crops or feed meant for livestock or other wildlife — it can be exceedingly difficult to remove enough animals from an established pig population to induce a population decline. In these situations, land managers may have to couple pig removal with long-term changes in land use or feeding practices to achieve success in reducing populations of wild pigs.

Although population eradication often is a best-case scenario, it is challenging to accomplish in most situations because of pigs' reproductive capacity, immigration from surrounding areas, and difficulty of finding and removing the last few remaining individuals (Hone 1983, Saunders and Bryant 1988, Choquenot et al. 1993). Nevertheless, eradication of wild pig populations has been accomplished in some

areas by using a combination of removal strategies (Schuyler et al. 2002, Cruz et al. 2005, McCann and Garcelon 2008). Eradication efforts probably have greatest opportunity for success in areas where pig populations are just beginning to become established or on islands (Schuyler et al. 2002, Cruz et al. 2005). Even in the absence of eradication, aggressive control programs can result in significant depopulation, which would solve many problems caused by wild pigs (Hone 1983). In Texas, for example, efforts to reduce the population sizes of wild pigs over 2 years resulted in a 66% decline in damage to agricultural crops and pastures (Higginbotham et al. 2008). In any depopulation program, it is important to conduct ongoing population surveys to assess the success of the program and the degree of population reduction (Richardson et al. 1997).

LETHAL TECHNIQUES

Trapping

Trapping is the most popular method for removing wild pigs from a population, and trapping programs — followed by euthanasia, not relocation — can reduce population density. Choquenot et al. (1993) found that an intense trapping program can reduce populations by 80 to 90%, but that some individuals are resistant to trapping; thus, trapping alone is unlikely to be successful in entirely eradicating populations. Unfortunately, little scientific literature exists to document which trap types and designs are most effective. Without a doubt, like most trapping, pig trapping is more art than science, and managers initiating a pig control program will quickly develop their own preferences and opinions. To that end, this section provides an overview of trapping strategies and techniques that managers can draw upon and apply in their own unique situations.

In general, cage traps, including both large corral traps and portable drop-gate traps, are most popular and effective, but success varies seasonally with the availability of natural food sources (Barrett and

Birmingham 1994). Cage or pen traps are based on a holding container with some type of a gate or door (Mapston 1999). Snares can also be effective but should be used cautiously in areas where livestock, deer, or other nontarget animals are present. Access points such as fence underpasses or pen entrances not used by nontarget animals are ideal locations for snares.

Pig trapping is more art than science.

Though traps can be effective and are probably the most common and preferred tactic for pig removal, managers should understand some potential problems associated with using them. Traps can be heavy and cumbersome, may entrap a variety of nontarget animals, and may elicit trap shyness among wild pigs. In addition, when several animals are caught, some may climb on top of others and escape over the side if the trap has no roof or other design



Chris Jaworowski

Placement of traps is important to success. Note that this trap was placed against an opening the pigs had pushed through this fence.

feature to minimize this occurrence (Mapston 1999). Furthermore, pigs may not be attracted to bait when natural sources of food are abundant, and trapping during these times can be ineffective. For example, Barrett and Birmingham (1994) documented that capture success is low during periods of heavy acorn production. Despite these problems and limitations, trapping is probably the most important tool in managers' arsenals for controlling wild pigs, and proper design can minimize many of these problems.

Bait

Many food items can be used for attracting wild pigs to traps or shooting sites. Shelled corn is likely the most popular choice, as it is effective and widely available, but reports from the field suggest that nontarget animals often find and consume the corn before pigs do. Since pigs are such generalist feeders, other food items that are perhaps less attractive to nontarget species can be used as bait. Carrion and sour grain are common selections; fermented corn or soybeans, in particular, are a favorite among many field biologists. Although these items are messier to work with than corn, they can reduce the attraction of nontarget animals to bait sites. In addition, some managers have developed mechanical feeding devices to reduce the consumption of corn by smaller nontarget animals like raccoons and wild turkeys.

A popular baiting device is a roll barrel, which is simply a large barrel (typically a 55-gallon drum) or section of large (8 inch or greater diameter) capped PVC pipe with multiple small holes (commonly 1 inch in diameter) distributed throughout and filled with corn or other pellet-type bait. Pigs are large and strong enough to move the barrel and thus extract corn from the barrel, while smaller animals are unable to do so.

Prebaiting can significantly increase the effectiveness of both trapping and shooting programs and should usually be considered standard practice when initiating a trapping program. Locking open the door of a trap and feeding bait for a period before

setting the trigger increases visitation to the trap and the likelihood of multiple captures (Mapston 1999).

Placement of the bait within the trap relative to the location of the trigger mechanism can be important, too. Some trappers advocate placing small amounts of bait in and around the door area, leading to larger quantities of bait around the trigger mechanism and as far from the door as possible. However, other trappers prefer just the opposite strategy: placing relatively large amounts of bait near the door with small amounts around the trigger mechanism. The rationale of this latter strategy is to maximize the opportunity for capturing larger numbers of pigs in a single trapping event. Theoretically, the larger amounts of bait near the door will attract the first few individuals without triggering the door, while following individuals will go to the remaining areas with feed around the trigger, thus making it possible to capture the entire group.

Cage Traps

Cage traps are by far the most common type of trap used to capture wild pigs. Stationary corral-type traps and more portable box traps have long been used for wild pig control with good success. Many, many different trap designs have been invented and promoted, and each trap inventor is likely convinced his or her design is superior to all others. In reality, however, several designs have been effective, and the exact design specifications are probably not as important as a few key principles.

First, when possible, traps should be large enough to trap and hold multiple pigs. The construction and maintenance of these stationary traps requires a significant investment in time and resources, and the ability to remove multiple pigs with each trap armament makes that investment more cost effective. Although mobility is sometimes important and may require smaller traps that are easy to move from site to site, the general rule for pig traps is that bigger is better.

Second, the trap must be sturdy enough to contain pigs once capture occurs. Adult pigs are large

and powerful, and trap materials and construction techniques must be able to withstand the forces exerted by captive animals. At a minimum, side panels should be constructed of 4-gauge welded fencing or its equivalent (typically sold at farm suppliers as cattle or hog panels). The trap should be anchored, at a minimum, with steel fence posts, and the framework should be made of material equivalent in strength to 2x4-inch or, better still, 4x4-inch dimensional lumber. Doors should be constructed of material equivalent in strength to $\frac{3}{4}$ -inch plywood or greater. In areas with particularly large pigs, even heavier materials should be used for gates and frames (Barrett and Birmingham 1994). Though wood certainly has been used successfully as a construction material for traps, steel is the better alternative for both strength and long-term durability.

Third, in most cases, delayed triggers should be used so multiple pigs can enter before the door trigger is engaged, thus increasing the probability of capturing multiple pigs each time. Two trigger designs that allow this are typically used — root sticks and trip wires — and they are described in greater detail later in this section.

Finally, traps should be designed so that pigs cannot escape by jumping or climbing. One method to prevent escape is the installation of a wire top (Barrett and Birmingham 1994), but this can cause unwanted mortality when deer, bears, or other nontarget animals are captured. In areas where capture of deer is a concern, the sides of the trap should be constructed of fence panels about 6 feet in height, which will enable most deer to escape while containing most pigs. In rectangular traps, pigs often congregate in the corners, thus providing an opportunity for individuals to climb on the backs of other pigs and escape over the top, even when using 6-foot or higher walls. To combat this problem, many managers advocate the construction of circular traps because pigs are less likely to congregate and thus escape by climbing out. A final option is the installation of “jump bars,” which are simply 4 bars installed parallel with the top edge of each trap panel. The bars are placed approximately

6 inches inside the trap edge and serve as a barrier to pigs attempting to climb out the top of the trap. In order to keep the bars secured in place, they are connected to each other at the four intersecting points by a pin or wire. Jump bars have proven quite effective at preventing escape from rectangular traps (personal communication, J. Dunlap, USDA/APHIS/Wildlife Services biologist, Florida).

In addition to large, stationary, corral-type traps, portable traps have been used effectively and can be moved from one area to another. These traps can be useful where wild pig occurrence is intermittent, when managers want to transport live pigs to another location, or when the terrain makes the installation of corral traps difficult (as in rocky soils where it is hard to install t-posts).

Often, the activities involved with setting up traps will push wild pigs into less disturbed areas. Adequate time should be given for them to return to the area before giving up and moving the traps to new locations. The best placement for all traps is in areas of high use, with signs like well-worn trails and wallows. When in operation, traps should be checked daily to be reset and rebaited when necessary. Loose barbed wire fencing around the outside of traps can help prevent livestock from entering and will protect bait material from some nontarget animals. When trapping is not occurring, trap doors should be locked open to prevent the accidental entrapment of nontarget animals and to perhaps allow resident pigs to become accustomed to an open trap.

Door Designs

An essential element of all cage traps is a door that allows pigs to enter the trap and, upon activation of the trigger, prevents



USDA/APHIS/Wildlife Services, Dana Johnson



USDA/APHIS/Wildlife Services, Chris Jaworowski

Adult pigs are large and powerful. Trap materials and construction techniques must be able to withstand the forces exerted by captive animals.



USDA/APHIS/Wildlife Services, John Dunlap

Jump bars are an effective tool to prevent pigs from escaping from rectangular cage traps. Four bars are installed a few inches away from the 4 top edges of the trap, and the intersections above each corner prevent animals from escaping from the backs of their fellow captives.



Chris Jaworowski

Wooden sliding doors like this one are easy to construct and work very well as part of any corral-style trap.



Chris Jaworowski

Swing doors pivot toward the inside of the trap, are held open with a trigger mechanism, and close with the aid of a spring mechanism. This door style is commonly used on portable cage traps.



Chris Jaworowski

The design of lift or rooter gates allow pigs to lift the door and enter the trap while preventing captured pigs from escaping.

pigs from leaving. The most important characteristic of trap doors is that they be large enough to allow individual pigs to enter without inadvertently triggering the door. As a general rule, door openings should be 32 inches wide or greater and at least 34 inches tall.

Although a plethora of door designs have been created, most fall within 3 broad categories: swing doors, fall doors, or lift doors.

Swing doors pivot toward the inside of the trap, are held open with a trigger mechanism, and close with the aid of a spring mechanism. Once closed, the spring mechanism and design keep the door closed and prevent pigs from exiting the trap.

Fall doors are initially suspended via a trigger line. Once triggered, gravity causes the door to slide or swing, thus entrapping individual pigs.

Lift or rooter doors exploit pigs' rooting tendency to create 1-way entries into traps. These doors are hinged at the top and tilted inward to the interior of the trap to allow pigs to root underneath the door and enter the trap, but not exit. Often, these doors are engineered to operate as a hybrid and incorporate the action of both fall and lift doors. Initially, the door is held open and suspended by the trigger line. Once the door is triggered and falls, however, it operates as a lift door and continues to allow pigs to enter the trap but prevents pigs from leaving.

As noted above, adult wild pigs can be large and strong. All components of the trap must be able to withstand the forces exerted by these animals, and this is especially true of the door mechanism. Doors can be easily built with dimensional lumber, but the most robust mechanisms are custom fabricated from steel to the

specifications of the trapper. For those managers not able or willing to pursue the construction of custom trap door mechanisms, commercial products are available from a variety of sources, mostly from small welding or machine shops scattered across the country. An example is the “hog slammer” swing door offered by Southern Outdoor Technologies, LLC (www.sportsmanscondo.com). Another company, Younger Bros. (www.younger-bros.com), offers a variety of commercial doors and traps. Readers interested in finding a local source for premade trap doors should contact others in the local area already involved with a pig trapping program; a local fabricator may already be making and selling doors or other trap components. If not, most welding or machine shops could construct such doors with simple plans and instructions.

Trigger Designs

Managers typically use 1 of 2 primary trigger designs when constructing traps: the root stick and the trip wire. In both cases, the trigger causes a line to be pulled, which causes the door to fall or swing closed. The root stick trigger design uses a stick wedged underneath holding stakes in or around the bait. The root stick is triggered as pigs in the act of feeding and rooting (hence the name “root stick”) push the root stick out from underneath the holding stakes and allow the door to fall.

The trip wire is the more sensitive of the 2 designs and can be triggered with relatively little pressure. Many derivations of the trip wire exist, but it is essentially a line or wire suspended just above the ground with a triggering device that releases and allows the door to close when pressure is exerted on the line.

Deciding which triggering device to use is largely a matter of personal preference and trial-and-error experimentation. Some trappers swear that the root stick is the better approach, as it takes some time for pigs to trip the device and presumably allows more individuals to enter the trap and be captured. Others, however, have cited evidence that root sticks have



Chris Jaworowski

Using simple materials and construction, the root stick is a reliable and time-tested triggering device.

a low capture rate and thus prefer trip wires as a triggering device (personal communication, C. Betsill, USDA/APHIS/Wildlife Services biologist, North Carolina). In either case, the triggering device should be placed on the opposite side of the trap from the door, which should provide some delay in tripping the trigger and allow as many individuals as possible to enter the trap and be captured.

Putting It All Together: Three Trap Designs

Within the scope of this publication, it is impossible to describe all the various trap designs for wild pigs; there are likely as many designs as there are individuals involved with trapping. Readers interested in exploring these possibilities need only search the Internet for “feral hog traps” or “wild pig traps” to find pictures and diagrams of traps with a wide range of sizes, configurations, and construction techniques. Instead of attempting to reflect that diversity here, we highlight 3 designs that should satisfy the needs of anyone interested in trapping pigs by showcasing one that is quick, easy, and cheap to construct; one that is

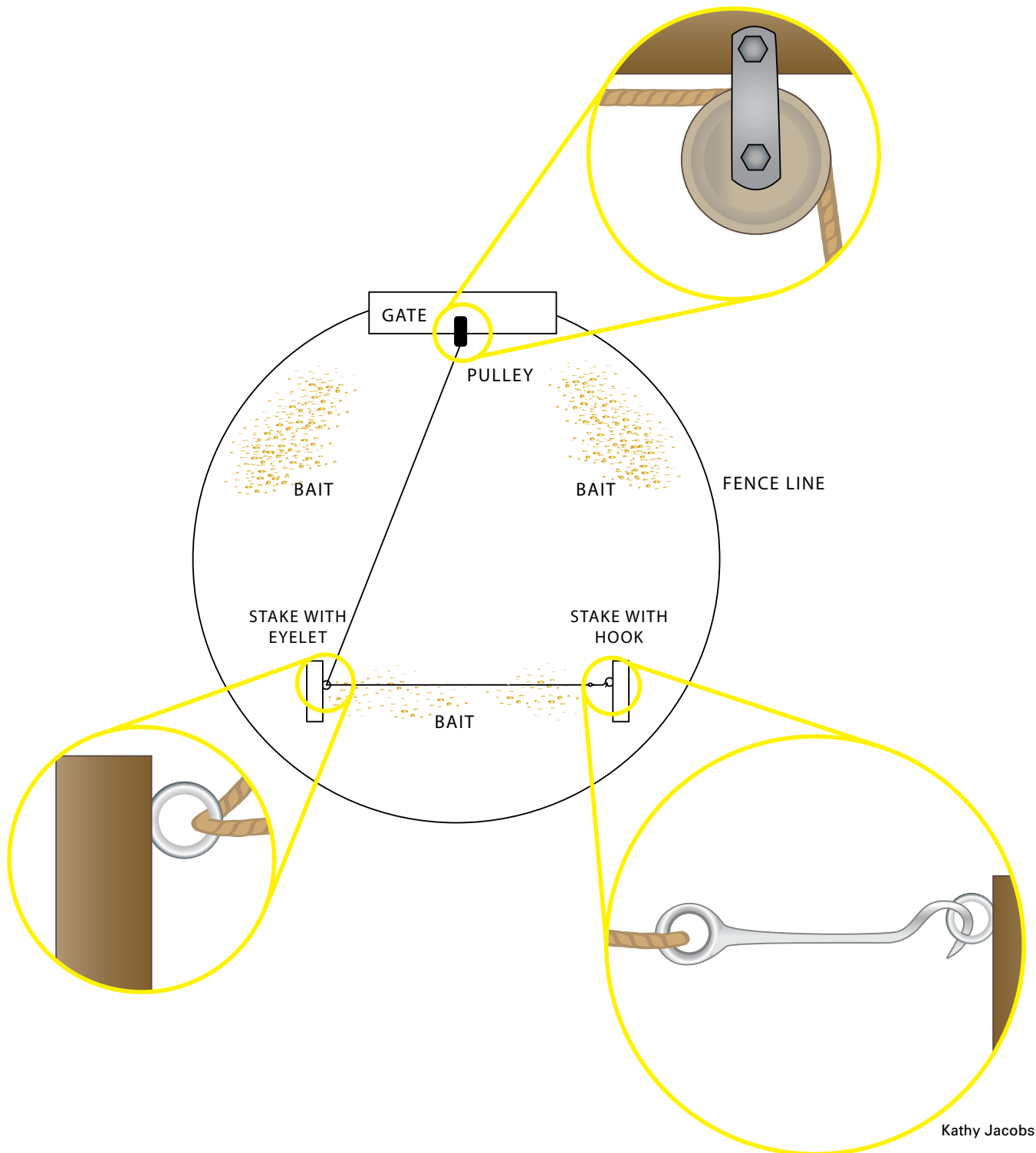

Kathy Jacobs

A trip wire in conjunction with a sliding trap door is a relatively simple mechanism that can be constructed from few materials. Every trapper has a different approach to constructing the trip wire, and many different configurations can work.

Also notice in this diagram the baiting strategy employed, which can be used for both trip wires and root sticks. By scattering bait heavily just inside the entrance and more lightly around the trip wire, the trapper increases the likelihood of having multiple pigs enter the trap before tripping the door. If bait were placed only around the trip wire or root stick, the first individual in would go directly to the bait and trip the door, thus leaving less time for other pigs to enter.

portable; and one that is large, complex, and expensive but very effective.

Design 1: The so-called *poor-man's special* is the essence of a simple and cheap pig trap. It is a 3-sided wire trap rigged with a wooden drop door. This trap can be constructed for little money, built by those with limited construction or fabrication skills, and moved relatively easily from site to site. The trap can be constructed using only 3 heavy-duty wire cattle panels, a dozen or so t-posts for reinforcement, and a homemade wooden drop door outfitted with either a root stick or trip wire triggering device. Although cheap and easy to build, this trap can capture several pigs at a time and does a reasonably good job of holding them securely, although some animals may escape at the corners by piling on their fellow captives and hopping out from their backs. With just a bit more time and effort, this trap can be constructed in a circular shape instead of a triangle and thus reduce the likelihood of crowding into corners and subsequent escape. All in all, this trap is a good choice for the landowner or managers just embarking upon the practice of wild pig trapping and is easily modified as needs and conditions change.

Design 2: The *portable cage trap* is a significant step up from the poor-man's special in terms of construction cost and complexity. Typically consisting of a welded steel frame and heavy wire panels, its construction is beyond the reach of those without significant fabrication skills. Those in need of such a trap may have to contact a local welding or fabrication shop about constructing one or buy one of the several commercially available units; again, a quick search on the Internet will yield many buying options. One of the traps displayed here features a spring-operated swing door,

while the other incorporates a rooter door. These smaller box traps will not allow capture of as many individuals as a larger corral-type trap, but they are highly portable and can easily be moved around from site to site, a vital characteristic for some managers. In Texas, traps like this are used to transport live pigs from the trapping location to various collection points, where the pigs are butchered and the meat sold to niche restaurants and markets.



Chris Jaworowski

Using a wooden sliding door and root stick trigger, the poor man's trap can capture multiple pigs in one setting.



USDA/APHIS/Wildlife Services, Dana Johnson

The poor man's trap is relatively simple and cheap to construct, yet it is fully capable of capturing many wild pigs. Using 3 cattle panels and a wooden sliding door, this trap can be constructed for little money, built by those with limited construction or fabrication skills, and moved relatively easily from site to site. For a bit more time and money, additional panels can be added to both make the trap larger and create a circular shape, thus lessening the tendency to crowd at the corners and potentially escape.

Design 3: The *large corral trap* outfitted with a robust door mechanism, such as the Kerrville Rooter Gate with Missouri Trigger, represents a top-of-the-line trap design. It is big enough to capture a large group of pigs, has a dual-function door that serves as both a fall door and, once triggered, as a lift door, and is robust enough to withstand any forces exerted on it. The unique door design functions first as a fall door that enables the capture of many pigs simultaneously. Once tripped, the door allows other pigs to root underneath and enter the trap but prevents captured pigs from leaving. In addition, the unique door is composed of 3 pieces so that smaller pigs, which would otherwise be unable to lift



Chris Jaworowski

The portable cage trap can be easily moved from site to site, a vital capability for some managers. This particular trap is outfitted with a rooter door.



Chris Jaworowski

On this portable cage trap, the designer used a spring-loaded swinging door, which can be very effective.

such a large door, can also root into the trap. Construction of such a door requires fairly complicated fabrication, however, so some managers may opt for a simpler design or choose to purchase one of the many offerings on the market. The rest of the trap, however, could be assembled by most individuals in a few hours. See the appendix for complete construction details for this trap.

Snares

Although probably not as widely used as some other tools, snares can be useful in specific situations, such as in rough terrain, where cage traps are impractical, or in scenarios where pigs grow wary of other trapping techniques. Furthermore, snares have distinct advantages over cage traps in the arenas of cost and portability. For these reasons, leg or, more typically, neck snares are often the tool of choice for wildlife managers. In Texas, for example, neck snares are the second-most-popular removal tool used by USDA/APHIS/Wildlife Services, ranking only behind aerial shooting.

Managers interested in using snares to remove wild pigs should note that snares set on land are not legal in many states. Individuals should check with local conservation officers to ascertain the specific legality of snares in their states as well as to inquire about the necessity of permits or licenses. Even when legally permissible, snares should be used with caution in areas where livestock, deer, and other nontarget species are present.

An ideal application for neck snares occurs under fences where wild pigs are accessing areas or on trails that pigs are traveling extensively. These areas can be identified by tracks and drag marks on the ground, hair on the fences, or arched-up

spots along the fences. Snares generally consist of a loop of galvanized aircraft cable 3/32 inch or 1/8 inch in diameter. The loop closes easily but will not open because of a sliding lock device. For minimum twisting and breakage, a heavy swivel should be used on the tie end of the snare to connect it to an anchor or drag (Mapston 1999). If a drag is to be used, the snare should be fastened to something fairly heavy, such as an oak limb 6 to 12 feet or more in length. The larger the pigs in the area, the larger the drag and heavier the cable needed (Barrett and Birmingham 1994).

Shooting and Hunting

Aside from trapping, shooting is likely the most common technique used to control wild pig populations. Shooting may occur within the context of recreational hunting, or it may be conducted by professionals as part of an intentional control program. In either case, shooting programs must be intense and consistent to reduce wild pig populations and associated damage effectively. Even then, shooting programs usually are most effective when combined with other efforts such as trapping.

Sport hunting can be used as a source of revenue for landowners and recreation for hunters and it may even appear to be an attractive control option to some wildlife managers. Nevertheless, sport hunting usually has little effect on the size of wild pig populations (Barret and Stone 1993). Sport hunting typically results in the removal of mostly adults, and this alone may not be enough to reduce the population (Bieber and Ruf 2005). In addition, hunting pressure can cause pigs to shift movements to cover and to develop more nocturnal feeding habits, thus resulting in a low hunter success rate (Barrett

and Birmingham 1994). Moreover, sport hunting may actually be detrimental in areas where trapping occurs, as the hunting pressure may cause pigs to shift away from the area, become more wary, and become less susceptible to trapping (Richardson et al. 1997).

Aerial Shooting

Aerial shooting is another option that can be extremely effective in some areas (Hone 1983). In fact, aerial shooting is perhaps



The Kerrville Rooter Gate with Missouri Trigger represents the top-of-the-line door mechanism for corral-type traps. This unique design allows the door to function first as a fall door with a trip-wire trigger and then, after it is triggered, to continue acting as a rooter door. What's more, the door is partitioned into 3 sections so that both very large adults and smaller juveniles can open the door and enter the trap. For details on construction, see the appendix.



Corral traps, when constructed properly, allow managers to capture large numbers of pigs efficiently. A trap like this one, outfitted with a Kerrville Rooter Gate with Missouri Trigger, is an outstanding tool for those interested in controlling pig populations.

the preferred control technique in landscapes such as those in Texas, which features low-growing vegetation, gentle topography, and a mild climate. In such areas, aerial shooting is so effective that, despite the high costs associated with aircraft, it can be the most cost-effective option, particularly when pig populations are high. As pig populations decline, however, aerial shooting produces diminishing returns and probably is not cost-effective at low population densities (Choquenot et al. 1999). In other areas, weather, heavy cover, and rough terrain limit the applicability of aerial shooting.

Sport hunting usually has little effect on the size of wild pig populations.

Night Shooting

When shooting over bait, the most effective approach is to conduct removal operations after dark with night vision technology and sound-suppressed weapons; before initiating this type of effort, though, be certain to check local and state regulations. In many states, agencies responsible for wild pig regulations will allow night shooting, and sound-suppressed weapons can be acquired under special permit. For shooting over bait, several days to a few weeks of prebaiting before shooting can greatly enhance the success of the removal operation.

Night shooting operations exploit the tendency of pigs to become nocturnal in response to human pressure and high temperatures, and they allow managers to use the cover of darkness. However, traditional night shooting approaches — shooting with a spotlight and conventional weaponry out of vehicles — offer many challenges and simply do not work well for wild pigs in most situations.

Fortunately, though, new technological developments have resulted in night vision equipment that greatly enhances the success of night shooting

operations. Technical advances in night vision equipment derived from military training are now being applied to wild pig control in the United States. Two types of equipment are available: systems that use near-infrared light and systems that use thermal imaging (Pinkston, unpublished report).

Systems that use near-infrared light have existed longer, and many people will recognize them by the characteristic greenish images they produce. Early versions of this equipment produced images with poor resolution, but newer equipment is remarkably clear. These devices work by collecting and amplifying visible light, including a portion of the infrared light spectrum otherwise undetectable to our eyes (Pinkston, unpublished report).

Thermal imaging works by capturing the portion of the infrared light spectrum that is emitted as heat by objects. Hot objects, such as warm-blooded animals, emit more light and show up as white when viewed in gray scale. Since this equipment works solely by capturing infrared energy from an object, no light at all is required for the device to function. Warm objects stand out against cooler backgrounds and become visible. Since the average body temperature of wild pigs is 102°F, they are easily detected while feeding in surroundings that have cooled to nighttime temperatures. Currently, the best thermal devices on the commercial market can detect these heat sources from more than 0.5 mile away (Pinkston, unpublished report). As these technologies improve, the devices are becoming smaller and more practical for commercial use. However, the price of night vision equipment, particularly of the thermal imaging type, is currently prohibitive for most landowners.

Using such equipment for night shooting, it may be possible to eliminate entire sounder groups feeding at night in open terrain. By using the cover of darkness, shooters can approach quite closely to groups of wild pigs. Shooters should target adults for initial shots and removal as juveniles offer easier follow-up shots once shooting commences. When the team consists of experienced shooters equipped with semi-automatic rifles, such operations can remove all

or most of the individual pigs in the field. Although the number of animals that can be removed with this technique is impressive, research has yet to assess the cost efficacy of this approach or its ability to reduce pig populations within a larger area. Increasingly, though, this is a preferred tool for biologists conducting disease surveillance, as it allows the sampling of pigs across a broad geographic area without the investment of time that would be required to set up traps in multiple locations.

Judas Pig

The “Judas pig” concept was adapted for use in wild pigs from a strategy of using radiotelemetry to find and control feral goats (Taylor and Katahira 1988). More recently, some managers in the United States have had success with the Judas technique with pigs (Wilcox et al. 2004, McCann and Garcelon 2008). In essence, the technique relies on tracking radio-tagged pigs to locate larger social groups, which can then be removed using a variety of methods. This technique has been used with some success in Australia (McIlroy and Gifford 1997, Australasian Wildlife Management Society 2006) and here in the United States (Wilcox et al. 2004, McCann and Garcelon 2008).

Managers have used a variety of techniques to capture individuals for radio tagging, including capture from helicopters and the use of dogs (Australasian Wildlife Management Society 2006), but cage traps are far and away the most common capture tool employed. Indeed, the cost efficiency of the Judas pig strategy is greatest when it can be integrated into an existing trapping program. Once captured, individuals are equipped with radio transmitting equipment (Braun 2005), visibly marked with paint



Thermal imaging equipment enables managers to find wild pigs easily at night.



Using thermal imaging at night, hunters can approach pig groups closely and optimize shooting opportunities.

or ear tags, and released. Subsequently, the tagged individuals will reintegrate with social groups and enable managers to locate large pig congregations.

Uncertainty remains about which individuals make the best subjects to serve as the Judas pig. Theoretically, because of their role as a social matron, adult females should be the best choice. However, ongoing research has failed to conclusively confirm this prediction, and others have actually suggested that adult males may be better suited to serve as the betraying individual (Australasian Wildlife Management Society 2006). In reality, the research conducted thus far was not large or comprehensive enough to

address this issue fully; more research is needed to help identify which type of pig (adult versus juvenile, male versus female) is most effective to radio tag and betray its cohorts.

Managers can use the knowledge of pig group locations in many ways to facilitate control. Although little research has been conducted in the United States regarding the Judas pig concept, Australian researchers have demonstrated its effectiveness in many ways. Managers in other countries have used knowledge of pig group locations to refine the placement of toxicant baits, thereby increasing effectiveness and decreasing cost (McIlroy and Gifford 1997). In addition, aerial shooting can be substantially more



Chris Jaworowski

The Judas pig. Some have speculated that radio-tagging a captured pig and releasing it can be a useful tool in tracking larger groups to target for control. However, this is a relatively new strategy, and more information is needed to understand when and where the Judas Pig technique would be effective.



Chris Jaworowski

effective using the Judas pig technique (Australasian Wildlife Management Society 2006), and anecdotal reports indicate similar increases in effectiveness for night shooting programs.

On the other hand, McCann and Garcelon (2008) evaluated the Judas pig technique to reduce pig populations on Pinnacle National Monument and concluded by being skeptical about the value of the technique. In any case, McCann and Garcelon (2008) recommended strongly that managers employing the Judas pig technique sterilize animals before releasing them back into the population, as they spent significant time removing offspring of their Judas pig subjects from the population.

Hunting with Dogs

Hunting with dogs can be effective at reducing wild pig populations in local areas and has been successfully used as part of larger control programs (Choquenot et al. 1996). In some cases, though, hunting with dogs simply causes pigs to move into adjacent areas. This shift in location can protect small, isolated, sensitive areas but may simply relocate the problem rather than alleviate it (Barrett and Birmingham 1994). On the other hand, some have speculated that harassment, such as that created by hunting with dogs, can cause home range shifts away from particular areas of concern and thus is a viable management technique (Engeman et al. 2006, Hayes 2007, Gaston 2008).

Many factors must be considered if hunting with dogs is to be successful. The experience of the dogs and hunters are integral elements in the success of this method. Poorly trained dogs, unseasoned hunters, hot weather, injuries, and the cost of good dogs, their training, and their care

can all be impediments to the success of this method (Mapston 1999). In many areas of the South, hunters often do not actually kill pigs during the hunt, but rather use dogs to help capture individual pigs, which are transported to a holding pen or another area. These practices are particularly troublesome as such transport can spread diseases and compromise broader control efforts. Those interested in using dog-assisted hunting as part of a management strategy should review the detailed account by Mayer et al. (2009).

Toxicants

No chemical toxicant is registered for use on wild pigs in the United States. However, the motivation to identify and register a toxicant for wild pigs is strong because it can be a powerful and cost-effective tool for controlling or eliminating animal populations. For example, Coblenz and Baber (1987) reported that poisoning was 11 times cheaper than shooting and 80 times cheaper than trapping during a pig eradication program in Ecuador. Thus, researchers are working to identify a toxicant that can humanely kill wild pigs while having a benign effect on nontarget animals and the larger environment.

No chemical toxicant is registered for use on wild pigs in the United States.

Toxicants are an effective and important tool for pig control in some countries, Australia and New Zealand in particular. Warfarin, an anticoagulant widely used as a rodent toxicant, has been used to control and nearly eliminate wild pig populations in Australia (Saunders et al. 1990). However, because of secondary poisoning and other environmental concerns, warfarin is not currently an option in the United States.

More recently, researchers in Australia have developed the product PIGOUT®, a bait containing the compound 1080, to achieve population reduction

of at least 73% (Cowled et al. 2006a). PIGOUT is designed to attract wild pigs and not other native wildlife species in Australia. During trials in Australia, which has no native mid-sized generalist mammals and thus is an environment where species-specific baits are viable, the product has shown great promise (Cowled et al. 2006b). Unfortunately, research in Texas demonstrated that many nontarget species (mostly mid-sized generalist mammals) would be adversely impacted by toxicant-laced PIGOUT baits in North American ecosystems, and thus it is currently not a viable alternative in the United States (Campbell et al. 2006).

Although PIGOUT has been shown to be effective in controlling pig populations in Australia without adversely affecting nontarget animals, some problems do exist with its use. Most notably, pigs are relatively insensitive to 1080, some perceive the toxin to cause an inhumane death, it can remain toxic in the carcass and environment, and there is no antidote if humans are accidentally exposed to the toxin. In search for answers to these problems with 1080, an Australian research team has identified another toxin, sodium nitrite, that reportedly causes a quick and humane death, is palatable yet toxic to wild pigs, is cheap and accessible, is degradable in the environment, and reduces risk to the operator as it has an effective antidote (Invasive Animals CRC 2008). Sodium nitrite already has undergone some preliminary pen trials, which are promising, and field trials are now under way in the form of a commercial formulation named HOG-GONE® (Cowled et al. 2008).

For any toxicant to become a viable technique in the United States, researchers must develop either toxicants or delivery systems that are species specific. Of these, development of a species-specific delivery system is most likely. Researchers are currently working to evaluate 2 delivery systems that were designed to deliver baits (that could be laced with either toxicants or contraceptive agents) to wild pigs while restricting access of other species. Researchers in the United Kingdom have developed the Boar Operated System (BOS), which consists of a bait

platform and sliding cover (Personal Communication, Giovanna Massei, United Kingdom Central Science Laboratory). Australian researchers have likewise developed a device to distribute baits to wild pigs but not to other species, the Boar Buffet® (Lapidge et al. 2009). Both of these systems exploit pigs' behavioral tendencies (feeding behavior) and physical traits (size and strength) to provide adult pigs access to bait, while limiting access to most other species. Some species like black bears, though, presumably could defeat the device. Although these devices show promise as a management tool, researchers have much work yet to do in evaluating their effectiveness and species specificity in various ecosystems.

NONLETHAL TECHNIQUES

Fencing

Excluding wild pigs with wire mesh fencing, electric fencing, or a combination of both can be an effective control measure. While few fence designs completely exclude pigs from an area, many fences can restrict pig movements. Though fences may restrict pig movements, they can be expensive to install and managers must ultimately consider the value of the commodity and cost of the fence before committing to this avenue of control (Conover 2002). Sturdy wire mesh fencing, particularly with the addition of an electrified wire about 6 to 8 inches off the ground, seems to be the most effective fence design to exclude wild pigs (Hone and Atkinson 1983).

Nonelectric fences should be of net wire or diamond mesh construction with a maximum of 6-inch spacing (Littauer 1993). To be effective in sheep- or goat-rearing areas, spacing should be no more than 4 inches to prevent livestock from sticking their heads through the fence. Fences should be at least 36 inches high, and the bottom wire should be tightly stretched on the ground surface or buried (Mapston 1999). While fencing can be an effective management technique, installing poorly designed or improperly constructed fences around areas in hopes of reducing



USDA/APHIS/Wildlife Services, Tyler Campbell

Research has demonstrated that electric fences can restrict the movement of wild pigs and thus have the potential to reduce damage. More extensive field testing is yet needed, though, to fully evaluate the practicality and cost effectiveness of this management tool.

pig damage can simply add the expense of frequent fence repair to the cost of damage (Beach 1993).

The addition of one or more electrified wires into existing net wire or other fences is possible and will reduce the likelihood of wild pigs penetrating the fence (Hone and Atkinson 1983, Littauer 1993). If installing new fences, though, simple electric fences with just a few electrified wires represent an attractive option because they are cheaper and easier to install than traditional net wire fencing. Reidy et al. (2008) reported that portable electric fences can significantly restrict, although not completely eliminate, the movement of pigs into a protected area. They found that simple electric fences consisting of only 2 electrified wires, one at 8 inches and one at 18 inches above the ground, were as effective as 3-wire designs and reduced daily intrusions of pigs into an area by 50%. Though initially cheap and easy to install, electric fences with low wires can require substantial

maintenance to prevent growing vegetation from contacting and grounding the electric wires.

Harassment

Human activity can have a substantive impact on pig behavior, movement, and survival. Although probably not an effective strategy on a large scale, harassment of pigs through hunting and pursuit may be a very effective technique for reducing pig populations and damage on small areas and for discrete resources. Engeman et al. (2003, 2006) reported that recreational hunting, even when few animals are actually harvested, reduced damage to sensitive wetland sites in Florida. Many have reported that pigs reduce or shift home ranges in response to hunting, trapping, and other harassment, and even that juvenile survival is reduced in the face of such pressure (Hayes 2007, Gaston 2008). On the other hand, Sodeikat and Pohlmeier (2003) found that pigs may temporarily flee an area in the face of intense hunting, but they often return to their original home range.

Human activity can have a substantive impact on pig behavior, movement, and survival.

Harassment, particularly through aggressive hunting, may be a viable technique for some managers, particularly those interested in protecting specific resources for a defined time period. On a larger scale, though, harassment has limited value and likely just shifts pig problems from one area to another. Some have even speculated that harassment leads to a greater risk of disease transmission (Sodeikat and Pohlmeier 2003) within the larger wild pig population.

Vaccination

Some studies have been conducted on the feasibility of vaccinating wild pig populations as a means of

protecting domestic stock and other wildlife. One study into the possibility of a brucellosis vaccination in the southeastern United States had positive results (Elzer 1999). By delivering a brucellosis vaccine orally in a mixture of corn syrup and pecan shells poured over corn, the researchers managed to vaccinate wild pigs. This method relies on the use of a viscous solution (corn syrup) to contain the vaccine combined with an oral scarification agent (pecan shells) to allow the vaccine direct access to tissues (Elzer 1999). Vaccination may become a nonlethal method to control disease spread in wild pig populations as further research improves upon economic feasibility and refines delivery techniques. However, this method is not currently viable for widespread use, nor does it alleviate myriad other problems associated with wild pig presence.

Contraception

Interest is strong in developing contraceptives capable of limiting wild pig populations over time. Some studies have shown injections of gonadotropin-releasing hormone (GnRH) to be effective in captive wild pigs (Killian et al. 2003). Results of GnRH injections included reduced ovary and testis weight, reduced levels of testosterone and progesterone, and reduced pregnancy rates in treated pigs when compared to controls (Killian et al. 2003). Unfortunately, these compounds are still under investigation and are currently available only in injection form, an unrealistic method for field application. Questions remain as to the duration of infertility, the reversibility of the effects, and whether an oral form of the vaccine—more conducive to wild pig management—can be developed.

One contraceptive vaccine being examined for approval and registration is GonaCon™. GonaCon is a single-shot, multiyear, GnRH immunocontraceptive vaccine that decreases sexual activity and prevents animals from entering a reproductive state through manipulation of hormones. Studies have shown that GonaCon Immunocontraceptive Vaccine suppresses reproduction in treated animals of both sexes and

keeps females infertile without boosting. However, this infertility is not permanent (lasting 1 to 4 years) and reverses on its own over time. Multiple injections increase the longevity of the vaccine (Miller et al. 2004). The GnRH vaccine has been shown to induce contraception in several mammalian species, including ground squirrels, domestic cats, domestic and feral pigs, and deer (Fagerstone et al. 2008). GonaCon is currently under review for possible approval as a restricted-use vaccine. For now, there are no contraceptives available for wild pigs.



Eddie Parham

The most successful wildlife damage management strategies employ a diversity of tactics in a comprehensive, integrated approach.

SUMMARY

Wild pigs are and will continue to be a challenging problem for wildlife managers, landowners, farmers, conservationists, and others. Despite ongoing control programs, wild pigs have increased both their range and population size. Because of this growth, wildlife managers will increasingly be involved in dealing with problems caused by wild pigs traditionally, as well as emerging problems such as landscaping damage in suburban areas. Certainly, wild pigs promise to be one of the more significant and challenging vertebrate wildlife pests for the foreseeable future. In response, wildlife professionals have dedicated significant effort to better manage problems caused by wild pigs, as more and more research, conferences, symposia, and articles in the profession are focused on pig-related issues (Ditchkoff and West 2007).

As Conover (2002) notes, human-wildlife conflicts are complex, and a myriad of ecological, biological, social, legal, and economic factors are involved. As a result, few wildlife problems have single or simple solutions. Instead, the most successful wildlife damage management strategies employ a diversity of tactics in a comprehensive, integrated approach. Without doubt, this principle is applicable to wild pigs. An integrated approach to wild pig management — where managers use a variety of techniques to remove pigs and prevent damage — is most effective (Choquenot et al. 1996, Mapston 1999). Wild pigs may quickly learn to avoid single control techniques but often have difficulty avoiding multiple techniques implemented in combination (Richardson et al. 1997). Nevertheless, it is

unlikely that individual landowners will be able to reduce pig populations, regardless of the intensity of control efforts on their individual properties. If a population reduction is desired, it almost certainly will require efforts across a geographic area larger than that of the average private landholding. In such cases, landowners may need to create partnerships among neighbors to jointly pursue the reduction of pig populations.

Successful management strategies will certainly depend upon persistent, adaptive, and integrated management programs that incorporate sound biological and ecological information (Campbell and Long 2009). These strategies alone, though, are insufficient. Because wild pigs reside principally on private lands over much of their range, astute wildlife managers will understand that stakeholder involvement and education are paramount to managing wild pig problems. As West (2009) articulates, the problems associated with wild pigs can be defined only within the context of human perceptions, experiences, and values. As such, an integrated management approach, in addition to addressing the biological and ecological aspects of wild pigs, will seek to engage stakeholders via comprehensive education and communication programs. We hope this guide can be a valuable tool in that crucial task.



Billy Higginbotham

Wild pigs can cause damage in a variety of areas, not just in agricultural fields. Here, pigs have caused significant damage to residential lawns in Texas. As the range and abundance of wild pigs increase, these kinds of problems will become more common.

LITERATURE CITED

- Adams, C. E., K. J. Lindsey, and S. J. Ash. 2006. The ecology and management considerations of selected species. Pages 239–286 in C. E. Adams, K. J. Lindsey, and S. J. Ash, editors. *Urban wildlife management*. CRC, Boca Raton, Florida, USA.
- Australasian Wildlife Management Society. 2006. Can Judas pigs be used for effective pig control in the New Zealand High Country? *Newsletter of the Australasian Wildlife Management Society* 20:5.
- Baber, D. W., and B. E. Coblenz. 1986. Density, home range, habitat use, and reproduction in feral pigs on Santa Catalina Island. *Journal of Mammalogy* 67:512–525.
- Baber, D. W., and B. E. Coblenz. 1987. Diet, nutrition, and conception in feral pigs on Santa Catalina Island. *Journal of Wildlife Management* 51:306–317.
- Barrett, R. H., and C. P. Stone. 1993. Hunting as a control method for wild pigs in Hawaii Volcanoes National Park: A report for resource management. Research division, Hawaii Volcanoes National Park Service, U.S. Department of the Interior, Hawaii National Park, Hawaii, USA.
- Barrett, R. H., and D. S. Pine. 1980. History and status of wild pigs, *Sus scrofa*, in San Benito County, California. *California Fish and Game* 67:105–17.
- Barrett, R. H., and G. H. Birmingham. 1994. Wild pigs. Pages D65–D70 in S. Hyngstrom, R. Timm, and G. Larsen, editors. *Prevention and control of wildlife damage*. Cooperative Extension Service, University of Nebraska, Lincoln, Nebraska, USA.
- Barrett, R. H. 1978. The feral hog at Dye Creek Ranch, California. *Hilgardia* 46:283–355.
- Beach, R. 1993. Depredation problems involving feral hogs. Pages 67–75 in C. W. Hanselka and J. F. Cadenhead, editors. *Feral swine: A compendium for resource managers*. Texas Agricultural Extension Service, Kerrville, Texas, USA.
- Belden, R. C. 1997. Feral hogs: The Florida experience. *Proceedings of the Feral Swine Symposium*. Accessed online at: <http://texnat.tamu.edu/symposia/feral/feral-14.htm>.
- Belden, R. C., and W. B. Frankenberger. 1989. History and biology of feral swine. Pages 3–10 in N. Black, editor. *Proceedings of the Feral Pig Symposium, April 27–29, 1989, Orlando, Florida, USA*. Livestock Conservation Institute, Madison, Wisconsin, USA.
- Belden, R. C., and W. B. Frankenberger. 1990. Biology of a feral hog population in south central Florida. *Proceedings of the Annual Conference of the Southeastern Association of Fish and Wildlife Agencies*, 44:231–249.
- Bieber, C., and T. Ruf. 2005. Population dynamics in wild boar *Sus scrofa*: ecology, elasticity of growth rate and implications for the management of pulsed resource consumers. *Journal of Applied Ecology* 42:1203–1213.
- Boitani, L., L. Mattei, D. Nonis, and F. Corsi. 1994. Spatial and activity patterns of wild boars in Tuscany, Italy. *Journal of Mammalogy* 75:600–612.
- Bratton, S. P. 1977. The effect of European wild boar on the flora of the Great Smoky Mountains National Park. Pages 47–52 in G. W. Wood, editor. *Research and management of wild hog populations*. Belle W. Baruch Forest Science Institute, Clemson University, Georgetown, South Carolina, USA.
- Braun, C. E., editor. 2005. *Techniques for wildlife investigation and management*, Sixth edition. The Wildlife Society, Bethesda, Maryland, USA.
- Bruce, J. 1941. Mostly about the habits of the wild boar. *California Conservationist*, 6:14, 21.
- California Food Emergency Response Team. 2007. Investigation of an *Escherichia coli* O157:H7 outbreak associated with Dole pre-packaged spinach. California Department of Health Services, Food and Drug Branch, Sacramento, California, USA.
- Campbell, T. A., and D. B. Long. 2009. Feral swine damage and damage management in forested ecosystems. *Forest Ecology and Management* 257:2319–2326
- Campbell, T. A., S. J. Lapidge, and D. B. Long. 2006. Using baits to deliver pharmaceuticals to feral swine in southern Texas. *Wildlife Society Bulletin* 34:1184–1189.

- Choquenot, D. J., R. J. Kilgour, and B. S. Lukins. 1993. An evaluation of feral pig trapping. *Wildlife Research*, 20:15–22.
- Choquenot, D., J. McIlroy, and T. Korn. 1996. *Managing vertebrate pests: Feral pigs*. Bureau of Resource Sciences, Australian Government Publishing Service, Canberra, Australia.
- Choquenot, D. J., J. Hone, and G. Saunders. 1999. Using aspects of predator-prey theory to evaluate helicopter shooting for feral pig control. *Wildlife Research* 26:251–261.
- Coblentz, B. E., and D. W. Baber. 1987. Biology and control of feral pigs on Isla Santiago, Galapagos, Ecuador. *Journal of Applied Ecology* 24:403–418.
- Conover, M. 2002. *Resolving human-wildlife conflicts: The science of wildlife damage management*. CRC Press, Boca Raton, Florida, USA.
- Corn, J. L., J. C. Cumbee, B. A. Chandler, D. E. Stallknecht, and J. R. Fischer. 2005. Implications of feral swine expansion: Expansion of feral swine in the United States and potential implications for domestic swine. Pages 295–297 in *Proceedings of the 109th Annual Meeting of the United States Animal Health Association*, Hershey, Pennsylvania, USA. Accessed online at: <http://www.usaha.org/meetings/proceedings.shtml>.
- Cowled, B. D., P. Elsworth, and S. J. Lapidge. 2008. Additional toxins for feral pig (*Sus scrofa*) control: Identifying and testing Achilles' heels. *Wildlife Research* 35:651–662.
- Cowled, B. D., E. Gifford, M. Smith, L. Staples, and S. J. Lapidge. 2006a. Efficacy of manufactured PIGOUT® baits for localized control of feral pigs in the semi-arid Queensland rangelands. *Wildlife Research* 33:427–437.
- Cowled, B. D., S. J. Lapidge, M. Smith, and L. Staples. 2006b. Attractiveness of a novel omnivore bait, PIGOUT®, to feral pigs (*Sus scrofa*) and assessment of risks of bait uptake by non-target species. *Wildlife Research* 33: 651–660.
- Cruz, F., C. J. Donlan, K. Campbell, and V. Carrion. 2005. Conservation action in the Galápagos: feral pig (*Sus scrofa*) eradication from Santiago Island. *Biological Conservation* 473–478.
- Cushman, J. H., T. A. Tierney, and J. M. Hinds. 2004. Variable effects of feral pig disturbances on native and exotic plants in a California grassland. *Ecological Applications* 14:1746–1756.
- Davidson, W. R., and V. F. Nettles, editors. 1997. Wild swine. Pages 104–133 in *Field manual of wildlife diseases in the southeastern United States*. Second edition. Southeastern Cooperative Wildlife Disease Study, Athens, Georgia, USA.
- Davidson, W. R., editor. 2006. Wild swine. Pages 105–134 in *Field manual of wildlife diseases in the southeastern United States*. Third edition. Southeastern Cooperative Wildlife Disease Study, Athens, Georgia, USA.
- Davis, D. S. 1993. Feral hogs and disease: implications for humans and livestock. Pages 84–87 in C. W. Hanselka and J. F. Cadenhead, editors. *Feral swine: A compendium for resource managers*. Texas Agricultural Extension Service, Kerrville, Texas, USA.
- Decker, E. 1978. Exotics. Pages 249–256 in Schmidt, J. L., and D. L. Gilbert, editors. *Big game of North America: ecology and management*. Stackpole Books, Harrisburg, Pennsylvania, USA.
- Ditchkoff, S. S., and B. C. West. 2007. Ecology and management of feral hogs. *Human-Wildlife Conflicts* 1:149–151.
- Engeman, R. M., A. Stevens, J. Allen, J. Dunlap, M. Daniel, D. Teague, and B. Constantin. 2006. Impacts of sport hunting and feral swine control on the conservation of seepage slopes at Eglin Air Force Base, Florida (abstract only). Page 15 in *2006 National Conference on Wild Pigs*. School of Forestry and Wildlife Sciences, Auburn University, May 21–23, Mobile, Alabama, USA.
- Engeman, R. M., H. T. Smith, S. A. Shwiff, B. Constantin, J. Woolard, M. Nelson, and D. Griffin. 2003. Prevalence and economic value of feral swine damage to native habitat in three Florida state parks. *Environmental Conservation* 30:319–324.
- Elzer, P. H. 1999. Vaccine delivery methods for feral swine now and in the future. Pages 94–97 in *Proceedings of the Feral Swine Symposium*. Texas Animal Health Commission, June 2–3, 1999, Fort Worth, Texas, USA.

- Fagerstone, K. A., L. A. Miller, J. D. Eisemann, J. R. O'Hare, and J. P. Gionfriddo. 2008. Registration of wildlife contraceptives in the United States of America, with OvoControl and GonaCon immunocontraceptive vaccines as examples. *Wildlife Research* 35: 586–592.
- Florida Department of Health. 2008. Florida Morbidity Statistics Report 2007. Tallahassee, Florida, USA.
- Fogarty, E. 2007. National distribution and stakeholder attitudes toward feral pigs. Thesis. Mississippi State University, Starkville, Mississippi, USA.
- Forrester, D. J. 1991. Parasites and diseases of wild mammals in Florida. University of Florida Press, Gainesville, Florida, USA.
- Frederick, J. M. 1998. Overview of wild pig damage in California. *Proceedings of the Vertebrate Pest Conference* 18:82–86.
- Gabor, T. M., E. C. Hellgren, R. A. Van Den Bussche, and N. J. Silvy. 1999. Demography, sociospatial behaviour and genetics of feral pigs (*Sus scrofa*) in a semi-arid environment. *Journal of Zoology (London)* 274:311–22.
- Gaston, W. D. 2008. Feral pig (*Sus scrofa*) survival, home range, and habitat use at Lowndes County Wildlife Management Area, Alabama. Thesis, Auburn University, Auburn, Alabama, USA.
- Geist, V. 1977. A comparison of social adaptations in relations to ecology in gallinaceous bird and ungulate societies. *Annual Review of Ecology and Systematics* 8:193–207.
- Giles, J. R. 1980. The ecology of feral pigs in western New South Wales. Ph.D. Dissertation, Sydney University, Sydney, Australia.
- Gipson, P., B. Hlabachick, and T. Berger. 1998. Range expansion by wild hogs across the central United States. *Wildlife Society Bulletin*. 26:279–286.
- Giuffra, E., J. M. H. Kijas, V. Amarger, O. Carlborg, J. T. Jeon, and L. Andersson. 2000. The origin of the domestic pig: Independent domestication and subsequent introgression. *Genetics*, 154:1785–1791.
- Graves, H. B. 1984. Behavior and ecology of wild and feral swine (*Sus scrofa*). *Journal of Animal Science* 58:482–492.
- Hanson, R. P., and L. Karstad. 1959. Feral swine in the southeastern United States. *Journal of Wildlife Management* 23:64–74.
- Hanson, L. B., M. S. Mitchell, J. B. Grand, D. B. Jolley, B. D. Sparklin, and S. S. Ditchkoff. 2009. Effect of experimental manipulation on survival and recruitment of feral pigs. *Wildlife Research* 36:185–191.
- Hayes, R. C. 2007. Feral hogs in central Mississippi: Home range, habitat use and survival. Thesis, Mississippi State University, Starkville, Mississippi, USA.
- Hellgren, E. C. 1993. Biology of feral hogs (*Sus scrofa*) in Texas. Pages 50–58 in C. W. Hanselka and J. F. Cadenhead, editors. *Feral swine: A compendium for resource managers*. Texas Agricultural Extension Service, Kerrville, Texas, USA.
- Herring, S. W. 1972. The role of canine morphology in the evolutionary divergence of pigs and peccaries. *Journal of Mammalogy*, 53:500–512.
- Higginbotham, B. G. Clary, L. Hysmith, and M. Bodenchuk. 2008. Statewide feral hog abatement pilot project, 2006–2007. Texas AgriLife Extension Service. Unpublished report. Accessed online at: <http://digitalcommons.unl.edu/feralhog/9>.
- Hone, J. 1983. A short-term evaluation of feral pig eradication at Willandra in Western New South Wales. *Australian Wildlife Research* 10:269–275.
- Hone, J., and B. Atkinson. 1983. Evaluation of fencing to control feral pig movement. *Australian Wildlife Research* 10:499–505.
- Hone, J., and H. Pedersen. 1980. Changes in a feral pig population after poisoning. *Proceedings of the Ninth Vertebrate Pest Conference* 9:176–182.
- Hone, J., R., Pech, and P. Yip. 1992. Estimation of the dynamics and rate of transmission of classical swine fever (hog cholera) in wild pigs. *Epidemiology and Infection* 108:377–386.
- Huff, M. H., 1977. The effect of the European wild boar (*Sus scrofa*) on the woody vegetation of gray beech forest in the

- Great Smoky Mountains. Southeast Region Uplands Field Resources Laboratory, Gatlinburg, Tennessee, USA.
- Hughes, T. W. 1985. Home range, habitat utilization, and pig survival of feral swine on the Savannah River Plant. Thesis, Clemson University, Clemson, South Carolina, USA.
- Hutton, T., T. DeLiberto, S. Owen, and B. Morrison. 2006. Disease risks associated with increasing feral swine numbers and distribution in the United States. Midwest Association of Fish and Wildlife Agencies, Wildlife and Fish Health Committee. Accessed online at: http://www.michigan.gov/documents/mda/Hutton_Pig_Paper_218759_7.pdf.
- Ilse, L., and E. Hellgren. 1995. Resource partitioning in sympatric populations of collared peccaries and feral hogs in southern Texas. *Journal of Mammalogy* 76:784–799.
- Invasive Animals CRC. 2008. Achilles heel approach—Finding a new humane feral pig toxin. Page 4 in *Uptake Update*, the newsletter of the Invasive Animals Cooperative Research Centre (www.invasiveanimals.com).
- Jedrzejewska, B., W. Jedrzejewski, A. N. Bunevich, L. Milkowski, and A. Krasinski. 1997. Factors shaping population densities and increased rates of ungulates in Bialowieza Primeval Forest in the 19th and 20th centuries. *Acta Theriologica* 42:399–451.
- Jolley, D. B. 2007. Reproduction and herpetofauna depredation of feral pigs at Fort Benning, Georgia. Thesis, Auburn University, Auburn, Alabama, USA.
- Jolley, D. B., S. S. Ditchkoff, B. D. Sparklin, L. B. Hanson, M. S. Mitchell, and J. B. Grand. 2010. An estimate of herpetofauna depredation by a population of wild pigs. *Journal of Mammalogy*: in press.
- Jones, P. 1959. The European wild boar in North Carolina. North Carolina Wildlife Resources Commission, Game Division, Raleigh, North Carolina, USA.
- Kaller, M. D. 2005. The macroinvertebrate community ecology of lowland, subtropical streams in Louisiana. Dissertation, Louisiana State University, Baton Rouge, Louisiana, USA.
- Kaller, M. D., and W. E. Kelso. 2006. Swine activity alters invertebrate and microbial communities in a coastal plain watershed. *American Midland Naturalist* 156:163–177.
- Kaller, M. D., J. D. Hudson III, E. C. Achberger, and W. E. Kelso. 2007. Feral hog research in western Louisiana: expanding populations and unforeseen consequences. *Human-Wildlife Conflicts* 1:168–177.
- Kaminski, G., S. Brandt, E. Baubet, and C. Baudoin. 2005. Life-history patterns in female wild boars (*Sus scrofa*): mother-daughter postweaning associations. *Canadian Journal of Zoology* 83:474–480.
- Killian, G., L. Miller, J. Rhyon, T. Dees, D. Perry, and H. Doten. 2003. Evaluation of GnRH contraceptive vaccine in captive feral swine in Florida. *Proceedings of the Wildlife Damage Management Conference* 10:128–133.
- Kurz, J. C., and R. L. Marchinton. 1972. Radiotelemetry studies of feral hogs in South Carolina. *Journal of Wildlife Management* 36:1240–1248.
- Landers, J. L., D. H. van Lear, and W. D. Boyer. 1995. The longleaf pine forests of the southeast: requiem or renaissance? *Journal of Forestry* 93:39–44.
- Lapidge, S., J. Wishart, M. Smith, and L. Staples. 2009. Is America ready for a human feral pig 'toxin'? *Proceedings of the Wildlife Damage Management Conference* 13: in press.
- Larson, G., K. Dobney, U. Albarella, M. Fang, E. Matisoo-Smith, J. Robins, S. Lowden, H. Finlayson, T. Brand, E. Willerslev, P. Rowley-Conwy, L. Andersson, and A. Cooper. 2005. Worldwide phylogeography of wild boar reveals multiple centers of pig domestication. *Science*, 307:1618–1620.
- Lewis, T. E., D. Atencio, R. Butgereit, S. M. Shea, and K. Watson. 1996. Sea turtle nesting and management in northwest Florida. Pages 162–164 in *Proceedings of the Fifteenth Annual Workshop on Sea Turtle Biology and Conservation*, February 20–25, 1995, Hilton Head, South Carolina, USA.
- Littauer, G. A. 1993. Control techniques for feral hogs. Pages 139–148 in *Feral swine: a compendium for resource managers*. Texas Agricultural Extension Service, San Angelo, Texas, USA.
- Lucas, E. G. 1977. Feral hogs — problems and control on National Forest lands. Pages 17–22 in G. W. Wood, editor. *Research and management of wild hog populations*. Belle

- Baruch Forest Science Institute, Clemson University, Georgetown, South Carolina, USA.
- Maehr, D. S., R. C. Belden, E. D. Land, and L. Wilkins. 1990. Food habits of panthers in southwest Florida. *Journal of Wildlife Management* 54:420–423.
- Mapston, M. E. 1999. Feral hog control methods. Pages 117–120 in *Proceedings of the Feral Swine Symposium*, June 2–3, 1999, Fort Worth, Texas, USA.
- Mayer, J. J. 2009 (In Press). Taxonomy and history of wild pigs in the United States. Pages 5–23 in J. J. Mayer and I. L. Brisbin, Jr., editors. *Wild Pigs: biology, damage, control techniques and management*. SRNL-RP-2009-00869. Savannah River National Laboratory, Aiken, South Carolina, USA.
- Mayer, J. J., and I. L. Brisbin, Jr. 1988. Sex identification of *Sus scrofa* based on canine morphology. *Journal of Mammalogy*, 69:408–412.
- Mayer, J. J., and I. L. Brisbin, Jr. 1991. *Wild pigs of the United States: their history, morphology and current status*. University of Georgia Press, Athens, Georgia, USA.
- Mayer, J. J., and I. L. Brisbin, Jr. 1993. Distinguishing feral hogs from introduced wild boar and their hybrids: A review of past and present efforts. Pages 28–49 in C. W. Hanselka and J. F. Cadenhead, editors. *Feral swine: A compendium for resource managers: proceedings of a conference*. Texas Agricultural Extension Service, College Station, Texas, USA.
- Mayer, J. J., and I. L. Brisbin, Jr. (Editors). 2009. *Wild pigs: Biology, damage, control techniques and management*. SRNL-RP-2009-00869. Savannah River National Laboratory, Aiken, South Carolina, USA: in press.
- Mayer, J. J., R. E. Hamilton, and I. L. Brisbin. 2009. Use of trained hunting dogs to harvest or control wild pigs. Pages 263–275 in Mayer, J. J., and I. L. Brisbin, Jr, editors. *Wild pigs: Biology, damage, control techniques and management*. SRNL-RP-2009-00869. Savannah River National Laboratory, Aiken, South Carolina, USA: in press.
- Mayer, J. J., E. A. Nelson, and L. D. Wike. 2000. Selective depredation of planted hardwood seedlings by wild pigs in a wetland restoration area. *Ecological Engineering*, 15(Supplement 1): S79–S85.
- Mayer, J. J., and C. B. Shedrow. 2007. Annotated bibliography of the wild pig (*Sus scrofa*). Washington Savannah River Company, Aiken, South Carolina, USA.
- McCann, B. E., and D. K. Garcelon. 2008. Eradication of feral pigs from Pinnacles National Monument. *Journal of Wildlife Management* 72:1287–1295.
- McIlroy, J. C., and E. J. Gifford. 1997. The 'Judas' pig technique: a method that could enhance control programmes against feral pigs, *Sus scrofa*. *Wildlife Research* 24(4):483–491.
- Miller, L. A., Rhyon, J., and Killian, G. 2004. GonaCon™: A versatile GnRH contraceptive for a large variety of pest animal problems. *Vertebrate Pest Conference* 21:269–273.
- Minagawa, M., A. Matsui, and N. Ishiguro. 2005. Patterns of prehistoric boar *Sus scrofa* domestication, and inter-islands pig trading across the East China Sea, as determined by carbon and nitrogen isotope analysis. *Chemical Geology*, 218:91–102.
- Minor, E. 2005. Experts say 'Hogzilla' was real and big. Associated Press, March 22, 2005.
- Mungall, E. C. 2001. Exotics. Pages 736–764 in S. Demarais and P. R. Krausman, editors. *Ecology and management of large mammals in North America*. Prentice Hall, Upper Saddle River, New Jersey, USA.
- Nettles, V.F., J. L. Corn, G. A. Erickson, and D. A. Jessup. 1989. A survey of wild swine in the United States for evidence of hog cholera. *Journal of Wildlife Diseases* 25:61–65.
- Nunley, G. L. 1999. The cooperative Texas wildlife damage management program and feral swine damage management. Pages 27–30 in *Proceedings of the Feral Swine Symposium*. Texas Animal Health Commission, June 2–3, 1999, Fort Worth, Texas, USA.
- Paarlberg, P., J. G. Lee, and A. H. Seitzinger. 2002. Potential revenue impact of an outbreak of foot and mouth disease in the United States. *Journal of the American Veterinary Medical Association* 220:988–992.

- Patten, D. C. 1974. Feral hogs — boon or burden. Proceedings of the Sixth Vertebrate Pest Conference 6:210–234.
- Pimentel, D., L. Lach, R. Zuniga, and D. Morrison. 2002. Environmental and economic costs associated with nonindigenous species in the United States. Pages 285–303 in D. Pimentel, editor. Biological invasions: economic and environmental costs of alien plant, animal, and microbe species. CRC, Boca Raton, Florida, USA.
- Pimentel, D. 2007. Environmental and economic costs of vertebrate species invasions into the United States. Pages 2–8 in G. W. Witmer, W. C. Pitt, and K. A. Fagerstone, editors. Managing vertebrate invasive species: Proceedings of an international symposium. USDA APHIS Wildlife Services, National Wildlife Research Center, Fort Collins, Colorado, USA.
- Pine, D. S., and G. L. Gerdes. 1973. Wild pigs in Monterey County, California. California Fish and Game, 59(2):126–137.
- Reidy, M. M., T. A. Campbell, and D. G. Hewitt. 2008. Evaluation of electric fencing to inhibit feral pig movements. Journal of Wildlife Management 72:1012–1018.
- Richardson, C. D., P. S. Gipson, D. P. Jones, and J. C. Luchsinger. 1997. Extirpation of a recently established feral pig population in Kansas. Proceedings of the Eastern Wildlife Damage Management Conference 7:100–103.
- Rollins, D. 1993. Statewide attitude survey on feral hogs in Texas. Pages 1–8 in C. W. Hanselka and J. F. Cadenhead, editors. Feral swine: A compendium for resource managers. Texas Agricultural Extension Service, Kerrville, Texas, USA.
- Rollins, D., B. J. Higginbotham, K. A. Cearley, and R. N. Wilkins. 2007. Appreciating feral hogs: extension education for diverse stakeholders in Texas. Human-Wildlife Conflicts 1:192–198.
- Romero, C. H., P. N. Meade, J. E. Shultz, H. Y. Chung, E. P. Gibbs, E. C. Hahn, and G. Lollis. 2001. Venereal transmission of pseudorabies viruses indigenous to feral swine. Journal of Wildlife Diseases 37:289–296.
- Rutledge, A. 1965. Demons of the delta. Sports Afield 153:68–69, 167–70.
- Saunders, G., K. Barry, P. Parker. 1990. Evaluation of a warfarin poisoning programme for feral pigs (*Sus scrofa*). Australian Wildlife Research 17:525–533.
- Saunders, G., and H. Bryant. 1988. The evaluation of a feral pig eradication program during a simulated exotic disease outbreak. Australian Wildlife Research 15:73–81.
- Saunders, G., and S. McLeod. 1999. Predicting home range size from the body mass or population densities of feral pigs, *Sus scrofa* (Artiodactyla: Suidae). Australian Journal of Ecology, 24:538–543.
- Schuyler, P. T., D. K. Garcelon, and S. Escover. 2002. Eradication of feral pigs (*Sus scrofa*) on Santa Catalina Island, California, USA. Pages 274–286 in C. R. Veitch and M. N. Clout, editors. Turning the tide: The eradication of invasive species. IUCN SSC Invasive Species Specialist Group, IUCN, Gland, Switzerland and Cambridge, United Kingdom.
- Schley, L, and T. J. Roper. 2003. Diet of wild boar *Sus scrofa* in Western Europe, with particular reference to consumption of agricultural crops. Mammal Review 33:43–56.
- Seward, N. W., K. C. VerCauteren, G. W. Witmer, and R. M. Engeman. 2004. Feral swine impacts on agriculture and the environment. Sheep and Goat Research Journal 19:34–40.
- Seymour, G. 1970. Wild pig: Sportsmen show increased interest in the European wild pig. State of California, Department of Fish and Game, Sacramento, California.
- Singer, F. J., W. T. Swank, and E. E. C. Clebsch. 1984. Effects of wild pig rooting in a deciduous forest. Journal of Wildlife Management. 48:464–473.
- Singer, F. J., D. K. Otto, A. R. Tipton, and C. P. Hable. 1981. Home ranges, movements, and habitat use of European wild boar in Tennessee. Journal of Wildlife Management 45:343–353.
- Sodeikat, G., and K. Pohlmeier. 2003. Escape movements of family groups of wild boar *Sus scrofa* influenced by drive hunts in Lower Saxony, Germany. Wildlife Biology 9(1):43–49.
- Sparklin, B. D., M. S. Mitchell, L. B. Hanson, D. B. Jolley, and S. S. Ditchkoff. 2009. Territoriality of feral pigs in a highly

- persecuted population on Fort Benning, Georgia. *Journal of Wildlife Management* 73:497–502.
- Springer, M. D. 1977. Ecological and economic aspects of wild hogs in Texas. Pages 37–64 in G. W. Wood, editor. *Research and management of wild hog populations: Belle Baruch Forest Science Institute of Clemson University, Georgetown, South Carolina, USA.*
- Stallknecht, D. E. and S. E. Little. 2009. Diseases and parasites of wild pigs. Pages 235–245 in Mayer, J. J., and I. L. Brisbin, Jr, editors. *Wild pigs: Biology, damage, control techniques and management.* SRNL-RP-2009-00869. Savannah River National Laboratory, Aiken, South Carolina, USA: in press.
- Stone, C. P., and J. O. Keith. 1987. Control of feral ungulates and small mammals in Hawaii's national parks: research and management strategies. Pages 277–287 in C. G. J. Richards and T. Y. Ku, editors. *Control of mammal pests.* Taylor and Francis, London, England, and New York and Philadelphia, USA.
- Sweeney, J. M. 1970. Preliminary investigations of a feral hog (*Sus scrofa*) population on the Savannah River Plant, South Carolina. Thesis, University of Georgia, Athens, Georgia, USA.
- Sweeney, J. M., and J. R. Sweeney. 1982. Feral hog. Pages 1099–1113 in J. H. Chapman and G. A. Feldhamer, editors. *Wild mammals of North America: biology, management, and economics.* Johns Hopkins University Press, Baltimore, Maryland, USA.
- Sweeney, J. R., J. M. Sweeney, and S. W. Sweeney. 2003. Feral hog. Pages 1164–1179 in G. A. Feldhamer, B. C. Thompson, and J. A. Chapman, editors. *Wild mammals of North America.* Johns Hopkins University Press, Baltimore, Maryland, USA.
- Sweeney, J. M., J. R. Sweeney, and E. E. Provost. 1979. Reproductive biology of a feral hog population. *Journal of Wildlife Management* 43:555–59.
- Sweitzer, R. A., and D. H. VanVuren. 2002. Rooting and foraging effects of wild pigs on tree regeneration and acorn survival in California's oak woodland ecosystems. USDA Forest Service General Technical Report PSW-GTR-184.
- Taylor, D., and L. Katahira. 1988. Radio telemetry as an aid in eradicating remnant feral goats. *Wildlife Society Bulletin* 16:297–299.
- Taylor, R. B. 2003. The feral hog in Texas. Texas Parks and Wildlife, Austin, Texas, USA. Unnumbered publication. Accessed online at: http://www.tpwd.state.tx.us/huntwild/wild/nuisance/feral_hogs.
- Taylor, R. B., E. C. Hellgren, T. M. Gabor, and L. M. Ilse. 1998. Reproduction of feral pigs in southern Texas. *Journal of Mammology* 79:1325–1331.
- Thompson, R. L. 1977. Feral hogs on National Wildlife Refuges. Pages 11–15 in G. W. Wood, editor. *Research and management of wild hog populations.* Belle W. Baruch Forest Science Institute, Clemson University, Georgetown, South Carolina, USA.
- Tolleson, D., D. Rollins, W. Pinchak, M. Ivy, and A. Hierman. 1993. Impact of feral hogs on ground-nesting gamebirds. Pages 76–83 in C. W. Hanselka and J. F. Cadenhead, editors. *Feral swine: A compendium for resource managers.* Texas Agricultural Extension Service, Kerrville, Texas, USA.
- United States Department of Agriculture (USDA). 2002. Environmental assessment: Management of predation losses to state and federally endangered, threatened, and species of special concern; and feral hog management to protect other state and federally endangered, threatened, and species of special concern, and candidate species of fauna and flora in the state of Florida. United States Department of Agriculture, Animal and Plant Health Inspection Services, Gainesville, Florida, USA.
- Wade, D. A., and J. E. Bowns, 1985. Procedures for evaluating predation on livestock and wildlife. Bulletin Number B-1429, Texas Agricultural Extension Service, Texas A&M University, San Angelo, Texas, USA.
- Waithman, J. D., R. A. Sweitzer, A. J. Brinkhaus, I. A. Gardner, D. Van Vuren, and W. M. Boyce. 1999. Range expansion, population sizes, and management of wild pigs in California. *Journal of Wildlife Management* 63:298–308.
- West, B. C. 2009. The human side of invasive species. *Human-Wildlife Conflicts* 3:6–7.

- Whitehouse, D. B. 1999. Impacts of feral hogs on corporate timberlands in the southeastern United States. Pages 108–110 in *Proceedings of the Feral Swine Symposium*, June 2–3, 1999, Ft. Worth, Texas, USA.
- Wilcox, J. T., E. T. Ashehoug, C. A. Scott, and D. H. Van Vuren. 2004. A test of the Judas technique as a method for eradicating feral pigs. *Transactions of the Western Section of the Wildlife Society* 40:120–126.
- Wilcox, J. T., and D. H. Van Vuren. 2009. Wild pigs as predators in oak woodlands of California. *Journal of Mammalogy*, 90:114–118.
- Williams, E. S., and I. K. Barker. 2001. *Infectious diseases of wild mammals*. Iowa State University Press, Ames, Iowa, USA.
- Wolf, T., and M. R. Conover. 2003. *Feral pigs and the environment: an annotated bibliography*. Berryman Institute Publication 21, Utah State University, Logan, Utah, USA; Mississippi State University, Starkville, Mississippi, USA. (Available online at www.berrymaninstitute.org.)
- Wood, G. W., and R. H. Barrett. 1979. Status of the wild pig in the United States. *Wildlife Society Bulletin* 36:237–246.
- Wood, G. W., and R. E. Brenneman. 1980. Feral hog movements and habitat use in coastal South Carolina. *Journal of Wildlife Management* 44(2):420–427.
- Wood, G. W., and T. E. Lynn, Jr. 1977. Wild hogs in southern forest. *Southern Journal of Applied Forestry* 1:12–17.
- Wyckoff, A. C., S. E. Henke, T. A. Campbell, D. G. Hewitt, and K. C. VerCauteren. 2009. Feral swine contact with domestic swine: a serologic survey and assessment of potential for disease transmission. *Journal of Wildlife Diseases* 45:422–429.
- Yarrow, G. K., and J. C. Kroll. 1989. Coexistence of white-tailed deer and feral hogs: management implications. *Southeast Deer Study Group* 12:13–14.

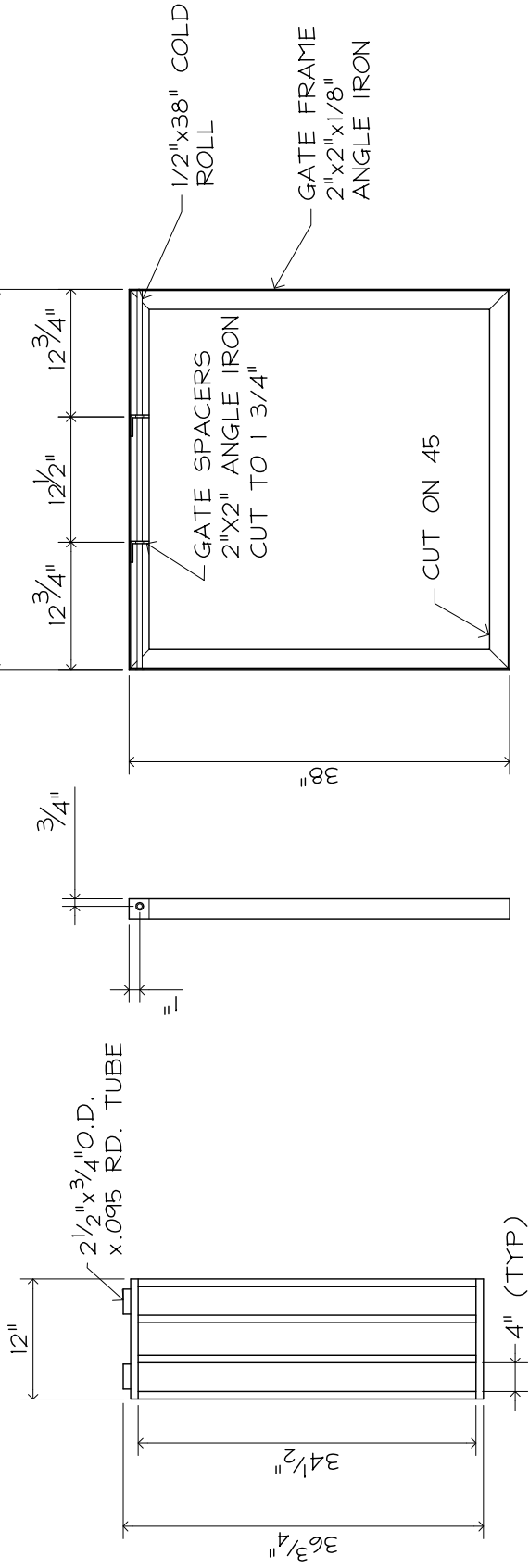

GATE DETAIL (TYPICAL OF 3)

SCALE: 3/4" = 1' - 0"

GATE FRAME DETAIL

SCALE: 3/4" = 1' - 0"

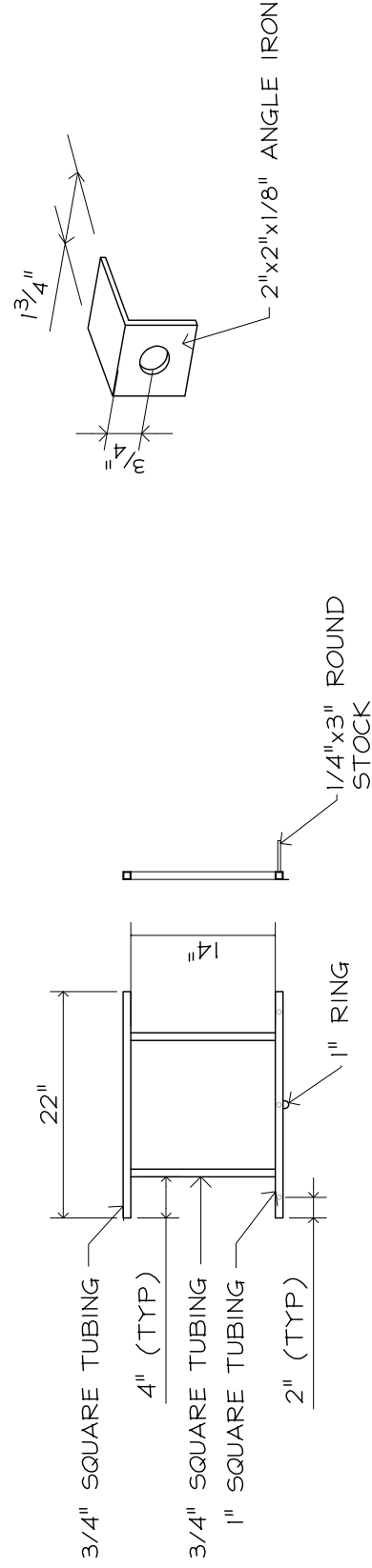

TRIGGER MECHANISM

SCALE: 3/4" = 1' - 0"

SPACER

SCALE: 3" = 1' - 0"



Kerrville Hog Rooter Gate w/ Trigger
Sht. 3

MATERIALS LIST:	
GATE FRAME:	TRIGGER MECHANISM:
14' - 2"x2"x1/8" ANGLE IRON	20' - 3/4"x3/4" 16 GAUGE Sq. TUBING
38" - 1/2" COLD ROLL	33" - 1"x1" Sq. 14 GAUGE TUBING
GATE:	9" - 1/4" ROUND STOCK
42' - 3/4"x3/4" 16 GAUGE Sq. TUBING	1 - 1" RING
15" - 3/4" OD ROUND TUBING w/.095 WALL	8" 2x2 ANGLE IRON
GATE PANEL:	OTHER SUPPLIES:
21' - 1" SCH. 40 PIPE	14.5 GAUGE WIRE, DOUBLED & TWISTED
	10 - 6'-6" 'T' POSTS
	3 - 4x4 WIRE PANELS 16' LONG x 5' MIN. HIGH

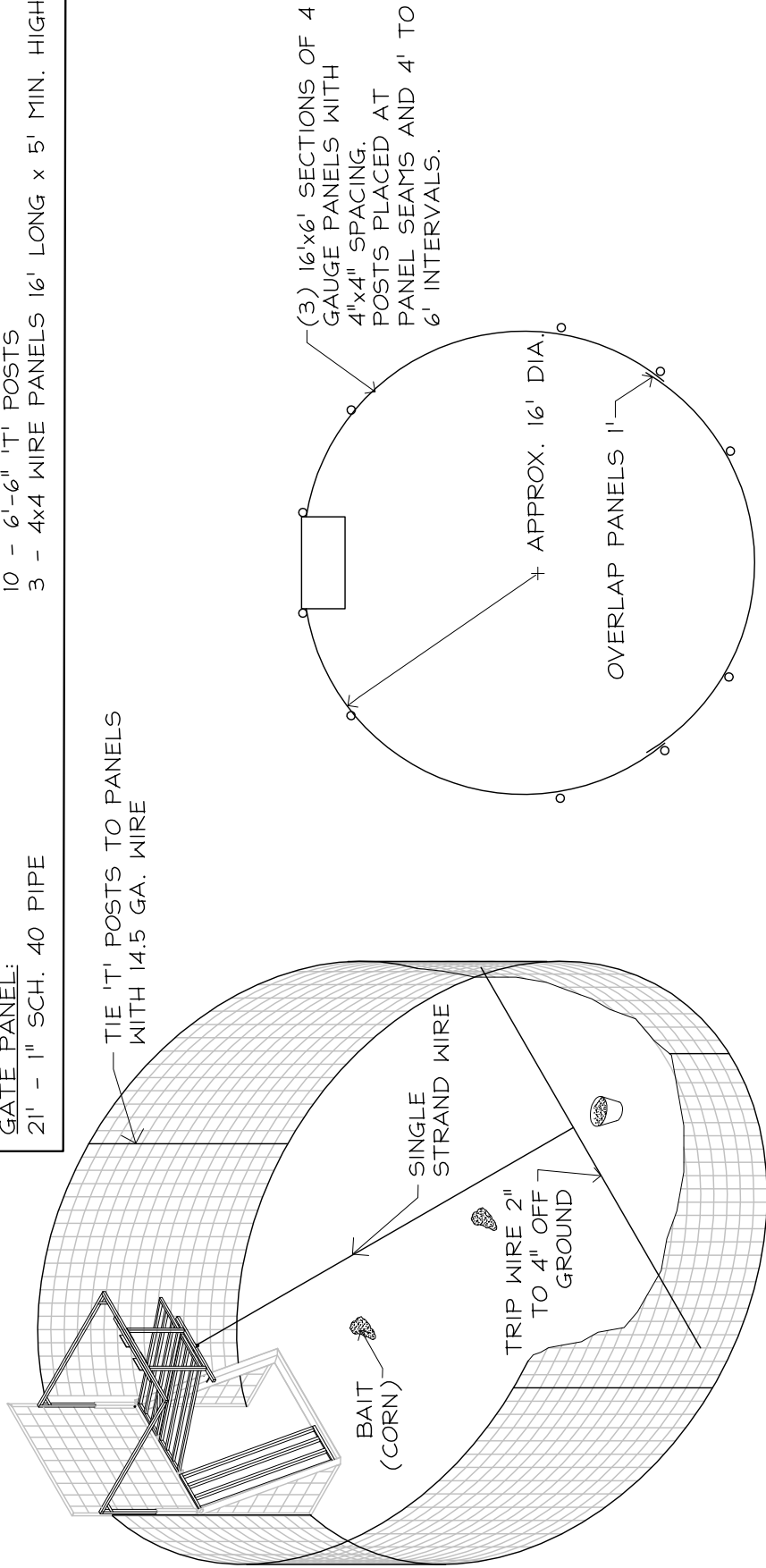

FENCE PLAN VIEW

SCALE: 3/16" = 1'-0"

FENCE ISOMETRIC VIEW

NOT TO SCALE



AUTHORS

BEN C. WEST

Ben earned degrees in natural resources and wildlife biology from the University of Tennessee-Martin (B.S.), Virginia Tech (M.S.), and Utah State University (Ph.D.). Since joining the faculty at Mississippi State University, Ben has been involved in a number of extension/outreach projects involving wildlife damage management. Now, as outreach coordinator for the Berryman Institute, Ben coordinates training and produces educational products for wildlife damage professionals nationwide.

ANDREA “ANDI” L. COOPER

Andi is a native Mississippian who attended Mississippi State University where she majored in Wildlife and Fisheries Science, Wildlife Science option. She received her Bachelor's in 2004 and master's degree in 2007. She currently holds a position with Ducks Unlimited's Southern Regional Office in Ridgeland, MS as their Communications Biologist and is responsible for the communications needs of the 15 states in the Southern Region.

JAMES “JIM” B. ARMSTRONG

Jim is a professor and coordinator for the Extension Forestry, Wildlife and Natural Resources Program for the Alabama Cooperative Extension System and Auburn University, School of Forestry and Wildlife Sciences. He has served as chair-elect/chair/past-chair of the Wildlife Damage Working Group of The Wildlife Society and has been a TWS-certified wildlife biologist since 1987. Jim's professional interests revolve around all aspects of wildlife damage management and human dimensions of wildlife management.

Support for this project was provided by



BERRYMAN INSTITUTE

Resolving Human-Wildlife Conflicts

MISSISSIPPI STATE
UNIVERSITY™

UtahState
University



United States Department of Agriculture
Animal and Plant Health Inspection Service
Wildlife Services





BERRYMAN INSTITUTE
Resolving Human-Wildlife Conflicts

Human-Wildlife
Interactions Monograph 1